

REGULATIONS AND SCHEDULE OF INTRASTATE CHARGES
APPLYING TO COMMUNICATIONS ACCESS SERVICES WITHIN
THE STATE OF CALIFORNIA

Issued: May 1, 2017

Resolution No:

Issued by:

Richard E. Ottalagana, Executive Vice President
One PaeTec Plaza, 600 Willowbrook Office Park
Fairport, New York 14450

May 8, 2017

Advice Letter No. 177

TABLE OF CONTENTS

	Leaf
Table of Contents	2
Concurring Carriers	3
Connecting Carriers	3
Other Participating Carriers	3
Symbols	4
Section 1 - General Regulations.....	5
Section 2 - Rules And Regulations	22
Section 3 - Switched Access	48
Section 4 - Direct Access	59
Section 5 - End User Access Service	72
Section 6 - Special Arrangements.....	73
Section 7 - Reciprocal Compensation Arrangements	76
Section 8 - Billing And Collection.....	77
Section 9 - Description and Application of Rates & Charges	94
Current Rates	96

Issued: May 1, 2017

Resolution No:

Issued by:

Richard E. Ottalagana, Executive Vice President
One PaeTec Plaza, 600 Willowbrook Office Park
Fairport, New York 14450

May 8, 2017

Advice Letter No. 177

CONCURRING CARRIERS

None

CONNECTING CARRIERS

None

OTHER PARTICIPATING CARRIERS

None

Issued: May 1, 2017

Resolution No:

Issued by:

Richard E. Ottalagana, Executive Vice President
One PaeTec Plaza, 600 Willowbrook Office Park
Fairport, New York 14450

May 8, 2017

Advice Letter No. 177

SYMBOLS

When changes are made in any tariff sheet, a revised sheet will be issued replacing the tariff sheet affected. Changes will be identified on the revised sheet through the use of the following symbols:

- (C) Indicates Changed Regulation
- (D) Indicates Discontinued Rate or Regulation
- (I) Indicated Rate Increase
- (M) Indicates Move in Location of Text
- (N) Indicates New Rate or Regulation
- (R) Indicates Rate Reduction
- (T) Indicates Change of Text Only

Issued: May 1, 2017

Resolution No:

Issued by:

Richard E. Ottalagana, Executive Vice President
One PaeTec Plaza, 600 Willowbrook Office Park
Fairport, New York 14450

May 8, 2017

Advice Letter No. 177

SECTION 1 - GENERAL REGULATIONS

1.1 APPLICATION OF TARIFF

This tariff contains regulations, rates and charges applicable to the provision of access services by PAETEC Communications, LLC to Customers. (T)

The provision of service by the Company as set forth in this tariff does not constitute a joint undertaking with the Customer for the furnishing of any service.

1.2 DEFINITIONS

ACCESS CODE - Denotes a uniform code assigned by the Company to an individual Customer. The code has the form 10XXX, 10XXXXX, 950-0XXX, or 950-1XXX.

ACCESS MINUTES - Denotes that usage of exchange facilities in intrastate service for the purpose of calculating chargeable usage.

ACCESS SERVICE – Includes services and facilities provided by the Company for the origination or termination of any intrastate telecommunications or origination or termination of other services utilizing the same PAETEC network services or functionality regardless of the technology used in transmission. This includes, but is not limited to, Internet Protocol or similar services to the extent subject to state regulatory jurisdiction.

ACCESS TANDEM - A switching system that provides a traffic concentration and distribution function for originating or terminating traffic between end offices and a Customer's premises.

ANSWER SUPERVISION - The transmission of the switch trunk equipment supervisory signal (off-hook or on-hook) to the Customer's point of termination as an indication that the called party has answered or disconnected.

CALL - A Customer attempt for which the complete address code is provided to the service end office.

CARRIER OR COMMON CARRIER - Any individual, partnership, association, corporation or other entity engaged in intrastate communication for hire by wire or radio between two or more exchanges.

CENTRAL OFFICE - A local Company switching system where exchange service customer station loops are terminated for purposes of interconnection to each other and to trunks.

SECTION 1 - GENERAL REGULATIONS (Cont'd)

1.2 DEFINITIONS (Cont'd)

CHANNEL - A communications path between two or more points of termination.

COMMUNICATIONS SYSTEM - Denotes channels and other facilities which are capable of communications between terminal equipment provided by other than the Company.

COMPANY - PAETEC Communications, LLC.

(T)

COMMISSION - The California Public Utilities Commission

CUSTOMER - The term "Customer(s)" denotes any individual, partnership, association, joint-stock company, trust, corporation, or governmental entity or other entity which subscribes to the services offered under this tariff, including but not limited to Interexchange Carriers (ICs), End Users and other telecommunications carriers or providers originating or terminating toll VoIP-PSTN traffic.

CUSTOMER DESIGNATED PREMISES - The premises specified by the Customer for termination of Access Services.

DUAL TONE MULTIFREQUENCY (DTMF) - Tone signaling, also known as touch tone signaling.

END OFFICE SWITCH - A Company switching system where exchange service customer station loops are terminated for purposes of interconnection to each other and to trunks.

END USER - Any customer of an intrastate telecommunications service that is not a Carrier or Common Carrier, except that a Carrier shall be deemed to be an End User when such Carrier uses a telecommunications service for administrative purposes. A person or entity that offers telecommunications service exclusively as a reseller shall be deemed to be an End User if all resale transmissions offered by such reseller originate on the premises of such reseller when making such service available to others, directly or indirectly.

Issued: May 1, 2017

Resolution No:

Issued by:

Richard E. Ottalagana, Executive Vice President
One PaeTec Plaza, 600 Willowbrook Office Park
Fairport, New York 14450

May 8, 2017

Advice Letter No. 177

SECTION 1 - GENERAL REGULATIONS (Cont'd)

1.2 DEFINITIONS (Cont'd)

ENTRY SWITCH - First point of switching.

EXCHANGE - A group of lines in a unit generally smaller than a LATA established by the Company for the administration of communications service in a specified area. An Exchange may consist of one or more central offices together with the associated facilities used in furnishing communications service within that area.

FACILITIES - Denotes any cable, poles, conduit, carrier equipment, wire center distribution frames, central office switching equipment, etc., utilized to provide the service offered under this tariff.

FIRST POINT OF SWITCHING - The first Company location at which switching occurs on the terminating path of a call proceeding from the Customer premises to the terminating end office and, at the same time, the last Company location at which switching occurs on the originating path of a call proceeding from the originating end office to the Customer premises.

INTERSTATE COMMUNICATIONS - Any communications with that crosses over a state boundary. Interstate Communications includes interstate and international communications.

INTRASTATE COMMUNICATIONS - Any communication which originates and terminates within the same state and is subject to oversight by a state regulatory commission as provided by the laws of the state involved.

LOCAL ACCESS AND TRANSPORT AREA (LATA) - A geographic area established for the provision and administration of communications service. A LATA encompasses designated exchanges, which are grouped to serve common social, economic and other purposes.

LOCAL CALLING AREA - A geographical area, as defined in the Company's local or general exchange service tariff in which an End User may complete a call without incurring toll usage charges.

MESSAGE - A Message is a Call as defined above.

Issued: May 1, 2017

Resolution No:

Issued by:

Richard E. Ottalagana, Executive Vice President
One PaeTec Plaza, 600 Willowbrook Office Park
Fairport, New York 14450

May 8, 2017

Advice Letter No. 177

SECTION 1 - GENERAL REGULATIONS (Cont'd)

1.2 DEFINITIONS (Cont'd)

NETWORK SWITCHING – Network Switching provides for the use of Company switching equipment and related network to originate or terminate an access minute of use of any type. It applies to the establishment and release of connections on a per call basis between two or more circuits, communications systems, alternative switches or services.

OFF-HOOK - The active condition of Switched Access Service or a telephone exchange line

ON-HOOK - The idle condition of Switched Access Service or a telephone exchange line.

ORIGINATING DIRECTION - The use of Switched Access Service for the origination of calls from an End User premises to a carrier's premises.

POINT OF TERMINATION - The point of demarcation within a customer-designated premises at which the Company's responsibility for the provision of access service ends. The point of demarcation is the point of interconnection between Company communications facilities and customer-provided facilities as defined in Part 68 of the Federal Communications Commission's Rules and Regulations.

PREMISES - A building or buildings on contiguous property, not separated by a public highway or right-of-way.

SERVING WIRE CENTER - The wire center from which the Customer-designated premises normally obtains dial tone from the Company.

SECTION 1 - GENERAL REGULATIONS (Cont'd)

1.2 DEFINITIONS (Cont'd)

SPECIAL ACCESS CIRCUIT - The physical pathway for transmission of information between a dedicated originating point and a dedicated terminating point.

TERMINATING DIRECTION - The use of Switched Access Service for the completion of calls from a carrier's premises to an End User premises.

TOLL VOIP-PSTN TRAFFIC - The term "Toll VoIP-PSTN Traffic" denotes a customer's interexchange voice traffic exchanged with the Telephone Company in Time Division Multiplexing format over PSTN facilities, which originates and/or terminates in Internet Protocol (IP) format. "Toll VoIP-PSTN Traffic" originates and/or terminates in IP format when it originates from and/or terminates to an end user customer of a service that requires IP-compatible customer premises equipment.

TRANSMISSION PATH - An electrical path capable of transmitting signals within the range of the service offering. A transmission path is comprised of physical or derived facilities consisting of any form or configuration of plant used in the telecommunications industry.

TRUNK - A communications path connecting two switching systems in a network, used in the establishment of an end-to-end connection.

TRUNK GROUP - A set of trunks which are traffic engineered as a unit for the establishment of connections between switching systems in which all of the communications paths are interchangeable.

WIRE CENTER - A physical location in which one or more central offices, used for the provision of exchange services, are located.

1.3 UNDERTAKING OF THE COMPANY

The Company shall be responsible only for the installation, operation and maintenance of service which it provides and does not undertake to transmit messages under this tariff.

Services provided under this tariff are provided 24 hours a day, seven days per week, unless otherwise specified in applicable sections of this tariff.

Issued: May 1, 2017

Resolution No:

Issued by:

Richard E. Ottalagana, Executive Vice President
One PaeTec Plaza, 600 Willowbrook Office Park
Fairport, New York 14450

May 8, 2017

Advice Letter No. 177

SECTION 1 - GENERAL REGULATIONS (Cont'd)

1.3 UNDERTAKING OF THE COMPANY (Cont'd)

1.3.1 LIABILITY OF THE COMPANY

The Liability of the Company for damages arising out of the furnishing of these services, including but not limited to mistakes, omissions, interruptions, delays, or errors, or other defects, representations, or use of these services or arising out of the failure to furnish the service, whether caused by acts of commission or omission, shall be limited to the extension of allowances as set forth in Section 1.6. The extension of such allowances shall be the sole remedy of the Customer, authorized user, or joint user and the sole liability of the Company.

The Company will not be liable for any special, consequential, exemplary or punitive damages a Customer may suffer, whether or not caused by the intentional acts or omissions or negligence of the Company's employees or agents.

The Company shall not be liable for any failure of performance or equipment due to causes beyond its control, including, but not limited to: acts of God, fire, flood or other catastrophes; any law, order, regulation, direction, action or request of the federal government, or of any other government, including federal and local governments having or claiming jurisdiction over the Company, or of any department, agency, commission, bureau, corporation, or other instrumentality of any one or more of these federal, state, or local governments, or of any civil or military authority; national emergencies; insurrections; riots; wars; unavailability of rights-of-way or materials; or strikes, lock-out, work stoppages, or other labor difficulties.

The Company shall not be liable for any act or omission of any entity furnishing to the Company or the Company's Customers facilities or equipment used for or with the services the Company offers.

The Company shall not be liable for any damages or losses due to the fault or negligence of the Customer or due to the failure or malfunction of Customer provided equipment or facilities.

Issued: May 1, 2017

Resolution No:

Issued by:

Richard E. Ottalagana, Executive Vice President
One PaeTec Plaza, 600 Willowbrook Office Park
Fairport, New York 14450

May 8, 2017

Advice Letter No. 177

SECTION 1 - GENERAL REGULATIONS (Cont'd)

1.3 UNDERTAKING OF THE COMPANY (Cont'd)

1.3.1 LIABILITY OF THE COMPANY (Cont'd)

The Company shall not be liable for the claims of vendors supplying equipment to Customers of the Company which may be installed at the premises of the Company nor shall the Company be liable for the performance of said vendor or vendor's equipment.

The Company does not guarantee nor make any warranty with respect to installations it provides for use in an explosive atmosphere. The Customer indemnifies and holds the Company harmless from any and all loss, claims, demands, suits, or other action, or any liability whatsoever, whether suffered, made, instituted, or asserted by any other party or person(s), and for any loss, damage, or destruction of any property, whether owned by the Customer or others, caused or claimed to have been caused directly or indirectly by the installation, operation, failure to operate, maintenance, removal, presence, condition, location, or use of any installation so provided.

The Company shall not be liable for any damages resulting from delays in meeting any service date due to delays resulting from normal construction procedures. Such delays shall include, but not be limited to, delays in obtaining necessary regulatory approvals for construction, delays in obtaining right-of-way approvals and delays in actual construction work.

The Company is not liable for any defacement of or damage to the premises of the Customer (or authorized or joint user) resulting from the furnishing of services or equipment on such premises or the installation or removal thereof, when such defacement or damage is not the result of negligence or willful misconduct on the part of the agents or employees of the Company.

The Company shall not be liable for any damages whatsoever associated with service, facilities, or equipment which the Company does not furnish or for any act or omission of Customer or any other entity furnishing facilities or equipment used for or in conjunction with the Company's service.

Issued: May 1, 2017

Resolution No:

Issued by:

Richard E. Ottalagana, Executive Vice President
One PaeTec Plaza, 600 Willowbrook Office Park
Fairport, New York 14450

May 8, 2017

Advice Letter No. 177

SECTION 1 - GENERAL REGULATIONS (Cont'd)

1.3 UNDERTAKING OF THE COMPANY (Cont'd)

1.3.1 LIABILITY OF THE COMPANY (Cont'd)

The Company makes no warranties or representations, express or implied either in fact or operation of law, statutory or otherwise, including warranties of merchantability and fitness for a particular use, except those expressly set forth herein.

1.3.2 CLAIMS

Company shall be indemnified and held harmless by Customer against all claims, suits, proceedings, expenses, losses, liabilities, or damages (collectively, "Claims:") arising from the use of the services pursuant to this Tariff involving: (1) Claims of third parties, including patrons or customers of Customer, arising out of, resulting from, or related to the use of the services; (2) Claims for libel, slander, invasion of privacy, or infringement of copyright arising from any communication using the services; (3) Claims for patent infringement arising from combining or using the facilities and equipment furnished pursuant to this Tariff in connection or in combination with facilities or equipment not furnished by the Company; and (4) all other Claims arisen out of any act or omission of Customers or patrons of Customer, in connection with the services made available to the Customer pursuant to this Tariff. Customer agrees to defend Company against any such Claims and to pay, without limitation, all litigation costs, reasonable attorney's fees and court costs, settlement payments, and any damages awarded or resulting from any such Claims.

1.3.3 TESTING, MAINTENANCE, AND ADJUSTING

Upon suitable notice, the Company may make such tests, adjustments, and inspections as may be necessary to maintain the Company facilities in satisfactory operating condition. No interruption allowance will be credited to the Customer for the periods during which the Company makes such tests, adjustments, or inspections.

Issued: May 1, 2017

Resolution No:

Issued by:

Richard E. Ottalagana, Executive Vice President
One PaeTec Plaza, 600 Willowbrook Office Park
Fairport, New York 14450

May 8, 2017

Advice Letter No. 177

SECTION 1 - GENERAL REGULATIONS (Cont'd)

1.3 UNDERTAKING OF THE COMPANY (Cont'd)

1.3.3 TESTING, MAINTENANCE, AND ADJUSTING (Cont'd)

The Company shall have no responsibility for the maintenance and repair of any kind with respect to equipment and facilities not provided by the Company. The Company will charge the Customer for any maintenance visits with respect to service problems which are determined to arise from equipment or facilities not provided by the Company

1.3.4 NON-ROUTING INSTALLATION

At the Customer's request, installation and/or maintenance may be performed outside the Company's regular business hours or in hazardous locations. In such cases, charges based on not less than the cost of actual labor, material, or other costs incurred by or charged to the Company will apply. If installation is started during regular business hours but extends beyond regular business hours into time periods including, but not limited to, weekends, holidays, and/or night hours, additional charges may apply.

1.3.5 OWNERSHIP OF FACILITIES

Title to all facilities provided in accordance with this Tariff remains in the Company, its agents or contractors. Customer shall not have, nor shall it assert, any right, title, or interest in all the facilities and associated equipment provided by the Company hereunder.

1.3.6 RIGHTS-OF-WAY

Any and all costs associated with obtaining and maintaining the rights-of-way from the point of entry at the Customer's location to the Customer, including but not limited to, the costs of installing conduit or of altering the structure to permit installation of Company provided facilities, shall be borne entirely by the Customer. Customer's use of such rights-of-way shall in all respects be subject to the terms, conditions, and restriction of such rights-of-way and of agreements between the Company and such third parties relating thereto, including without limitation, the

Issued: May 1, 2017

Resolution No:

Issued by:

Richard E. Ottalagana, Executive Vice President
One PaeTec Plaza, 600 Willowbrook Office Park
Fairport, New York 14450

May 8, 2017

Advice Letter No. 177

SECTION 1 - GENERAL REGULATIONS (Cont'd)

1.3 UNDERTAKING OF THE COMPANY (Cont'd)

1.3.6 RIGHTS-OF-WAY (Cont'd)

duration applicable to and the condemnation of such rights-of-way, and shall not be in violation of any applicable governmental ordinance, law, rule, regulation or restriction. Where applicable, Customer agrees that it shall assist Company in the procurement and maintenance of such right-of-way.

1.3.7 SERVICES PROVIDED BY OTHER CARRIERS

Company shall have no responsibility with respect to billings, charges, or disputes related to services used by Customer, which are not included in the services herein, including, without limitation, any local, regional, and long distance services not offered by the Company. Customer shall be fully responsible for the payment of any bills for such services and for the resolution of any disputes or discrepancies with the service provider.

1.3.8 GOVERNMENTAL AUTHORIZATIONS

The provision of services under this Tariff is subject to and contingent upon the Company obtaining and retaining such approvals, consents, governmental authorizations, licenses and permits, as may be required or be deemed necessary by the Company. Company shall use reasonable efforts to obtain and keep in effect all such approvals, consents, authorizations, licenses and permits that may be required to be obtained by it. Company shall be entitled to take, and shall have no liability whatsoever for, any action necessary to bring the services into conformance with any rules, regulations, orders, decisions, or directives imposed by the Public Utilities Commission or other applicable agency, and Customer shall fully cooperate in and take such action as may be requested by Company to comply with any such rules, regulations, orders, decisions or directives.

Issued: May 1, 2017

Resolution No:

Issued by:

Richard E. Ottalagana, Executive Vice President
One PaeTec Plaza, 600 Willowbrook Office Park
Fairport, New York 14450

May 8, 2017

Advice Letter No. 177

SECTION 1 - GENERAL REGULATIONS (Cont'd)

1.3 UNDERTAKING OF THE COMPANY (Cont'd)

1.3.9 ASSIGNMENT

The Company may, without obtaining any further consent from Customer, assign any rights, privileges, or obligations under this Tariff. Customer shall not, without prior written consent of Company, which consent shall not be unreasonably withheld, assign, transfer, or in any other manner dispose of, any of its rights, privileges, or obligations under this Tariff, and any attempt to make such an assignment, transfer, disposition without consent shall be null and void.

1.3.10 NETWORK MANAGEMENT

The Company will administer its network to insure the provision of acceptable service levels to all users of the Company's network services. Generally, service levels are considered acceptable only when both end users and customers are able to establish connections with little or no delay encountered within the Company's network.

The Company maintains the right to apply protective controls, i.e., those actions such as call gapping, which selectively cancels the completion of traffic, over any traffic carried over its network. These measures would only be taken as a result of occurrences such as failure or overload of Company or Customer facilities, natural disasters, mass calling or national security demands. In the event that the protective controls applied by the Company result in the complete loss of service to the Customer, the Customer will be granted a Credit Allowance for Service Interruptions as set forth below.

1.3.11 ALLOWANCES FOR INTERRUPTION IN SERVICE

A credit allowance will be given for any period during which any line subscribed to by Customer hereunder is out of service, except as specified below. Out of service conditions are defined as complete loss of call origination and/or receipt capability. Credit allowances, if any shall be deducted from the charges payable by Customer hereunder and shall be expressly indicated on the next bill to Customer. A credit allowance will be made when an interruption occurs because of a failure of any component furnished under this Tariff by Company.

Issued: May 1, 2017

Resolution No:

Issued by:

Richard E. Ottalagana, Executive Vice President
One PaeTec Plaza, 600 Willowbrook Office Park
Fairport, New York 14450

May 8, 2017

Advice Letter No. 177

SECTION 1 - GENERAL REGULATIONS (Cont'd)

1.3 UNDERTAKING OF THE COMPANY (Cont'd)

1.3.11 ALLOWANCES FOR INTERRUPTION IN SERVICE (Cont'd)

An interruption period begins when the Customer reports a service to be interrupted and releases it for testing and repair. An interruption period ends when the service is operative. If the Customer reports the service to be inoperative but declines to release it for testing and repair, it is considered to be impaired, but not interrupted.

For calculating credit allowances, every month is considered to have thirty (30) days. A credit allowance is applied on a pro rata basis against the rates specified hereunder and is dependent upon the length of the interruption. Only those services on the interrupted portion of the circuit will receive a credit.

In case of an interruption to any service, allowance for the period of interruption, if not due to the negligence of the Customer, shall be as follows:

1.3.11.1 For Monthly Recurring Charges, no credit allowance will be given on interruptions less than thirty (30) minutes. The Customer shall be credited for an interruption of 30 minutes or more at the rate of 1/1440 of the monthly charge for the service for each period of 30 minutes or at least 15 minutes thereof that the interruption continues.

1.3.11.2 For usage based charges, no credit will be allowed for an interruption less than 24 hours. The customer shall be credited for an interruption of 24 hours or more at the rate of 1/30 of: a) the monthly rates; b) the assumed minutes of use charge; or c) the minimum monthly usage charge, whichever is applicable, for each period of 24 hours or major fraction (12 hours and 1 minute) thereof that the interruption continues. However, in the case of the service billed based on actual usage, no credit allowance will be given when the actual usage charge exceeds the minimum monthly usage charge in any one monthly billing period.

Issued: May 1, 2017

Resolution No:

Issued by:

Richard E. Ottalagana, Executive Vice President
One PaeTec Plaza, 600 Willowbrook Office Park
Fairport, New York 14450

May 8, 2017

Advice Letter No. 177

SECTION 1 - GENERAL REGULATIONS (Cont'd)

1.3 UNDERTAKING OF THE COMPANY (Cont'd)

1.3.11 ALLOWANCES FOR INTERRUPTION IN SERVICE (Cont'd)

No credit allowance will be made for:

Interruptions due to the negligence of, or non-compliance with the provisions of the Tariff by the Customer, authorized user, joint user, or other common carrier providing service connected to the service of the Company;

Interruptions of service due to the failure or malfunction of facilities, power, or equipment provided by the Customer, authorized user, joint user, or other common carrier providing service connected to the service offered by the Company;

Interruptions of service during any period in which the Company is not given access to the premises at which the Company provided service is interrupted or terminated;

Interruptions of service that occur or continue due to the Customer's failure to authorize replacement of any element of special construction;

Interruptions of service during any period when the Customer, authorized user, or joint user has released service to the Company for maintenance purposed or for implementation of a Customer order for a change in service arrangements;

Interruptions of service due to circumstances beyond the control of the Company.

1.3.12 TRANSMISSION SPECIFICATIONS

The Company's transmission path will meet the standard transmission specifications as set forth in Bellcore Technical Publications. When the Company uses facilities and services from other service providers, the Company's transmission paths will conform to Bellcore Technical Publications, to the extent that the supplying service provider's facilities and services meet the specifications. The Company will, upon notification by the Customer that the date parameters set forth are not being met,

Issued: May 1, 2017

Resolution No:

Issued by:

Richard E. Ottalagana, Executive Vice President
One PaeTec Plaza, 600 Willowbrook Office Park
Fairport, New York 14450

May 8, 2017

Advice Letter No. 177

SECTION 1 - GENERAL REGULATIONS (Cont'd)

1.3 UNDERTAKING OF THE COMPANY (Cont'd)

1.3.12 TRANSMISSION SPECIFICATIONS (Cont'd)

conduct tests independently or in cooperation with the Customer, and take any actions deemed by the Company to be necessary to insure that the data parameters are met.

1.3.13 PROVISION OF SERVICE PERFORMANCE DATA

Subject to availability, end-to-end service performance data available to the Company through its own service evaluation routines may also be made available to the Customer based on previously arranged intervals and format.

1.3.14 ACCEPTANCE TESTING

At no additional charge the Company will, at the Customer's request and where applicable, cooperatively test at the time of installation the following parameters: loss, C-notched noise, C-message noise, 3-tone slope, d.c. continuity, and operations signaling. Balance parameters may also be tested where applicable.

1.3.15 ROUTINE TESTING

At no additional charge the Company will, at the Customer's request and where applicable, test after installation on an automatic or manual basis, 1004 Hz loss, C-message noise, and Balance (Return loss). In the case of automatic testing, the Customer shall provide remote office test lines and 105 test lines with associated responders or their functional equivalent. The frequency of the tests will be as mutually agreed on by the Customer and the Company, but shall consist of not less than quarterly 1004 Hz loss and C-message noise tests, and an annual balance test. Trunk test failures requiring Customer participation for trouble resolution will be provided to the Customer on an as-occurs basis.

Issued: May 1, 2017

Resolution No:

Issued by:

Richard E. Ottalagana, Executive Vice President
One PaeTec Plaza, 600 Willowbrook Office Park
Fairport, New York 14450

May 8, 2017

Advice Letter No. 177

SECTION 1 - GENERAL REGULATIONS (Cont'd)

1.3 UNDERTAKING OF THE COMPANY (Cont'd)

1.3.16 DETERMINATION OF THE NUMBER OF TRANSMISSION PATHS

The Customer will determine the number of switched access service transmission paths to be provided for the busy hour minutes of capacity ordered. The Company can assist the Customer in developing the number of transmission paths using standard company engineering methods.

1.3.17 TRUNK GROUP MEASUREMENT REPORTS

Subject to availability, the Company will make available to the Customer trunk group data in the form of usage in CCS, peg count and overflow, at previously agreed to intervals.

1.4 PROHIBITED USES

The services the Company offers shall not be used for any unlawful purpose or for any use as to which Customer has not obtained all governmental approvals, authorization, licenses, consents and permits required to be obtained by the Customer with respect hereto.

The Company may require applicants for service who intend to use the Company's offerings for resale and/or for shared use to demonstrate that their use of the Company offerings complies with relevant laws, regulations, policies, orders, and decisions.

The Company may require a Customer to immediately shut down its transmission of signals if said transmission is causing interference to others.

A Customer may not use the services so as to interfere with or impair service over any facilities and associated equipment, or so as to impair the privacy of any communications over such facilities and associated equipment.

Customer use of any service obtained from other service providers by the Company and resold to Customer shall also be subject to any applicable restrictions in the underlying providers' publicly available tariffs.

SECTION 1 - GENERAL REGULATIONS (Cont'd)

1.4 PROHIBITED USES (Cont'd)

A Customer, joint user, or authorized user shall not represent that its services are provided by the Company, or otherwise indicate to its customers that its provision of services is jointly with the Company, without the written consent of the Company. The relationship between Company and Customer shall not be that of partners or agents for one of the other, and shall not be deemed to constitute a partnership or agency agreement.

Issued: May 1, 2017

Resolution No:

Issued by:

Richard E. Ottalagana, Executive Vice President
One PaeTec Plaza, 600 Willowbrook Office Park
Fairport, New York 14450

May 8, 2017

Advice Letter No. 177

SECTION 2 - RULES AND REGULATIONS

2.1 USE OF FACILITIES AND SERVICES

2.1.1 Use of Service

1. Service may be used for any lawful purpose by the Customer or by any End User.
2. The Customer obtains no property right or interest in the use of any specific type of facility, service, equipment, number, process, or code. All right, title and interest to such items remain, at all times, solely with the Company.
3. Recording of telephone conversations of service provided by the Company under this tariff is prohibited except as authorized by applicable federal, state and local laws.
4. Any service provided under this Tariff may be resold to or shared (jointly used) with other persons at the Customer's option. The Customer remains solely responsible for all use of service ordered by it or billed to its account(s) pursuant to this Tariff, for determining who is authorized to use its service, and for promptly notifying the Company of any unauthorized use. The Customer may advise its customers that a portion of its service is provided by the Company, but the Customer shall not represent that the Company jointly participates with the Customer in the provision of the service.
5. Use of the facilities and services in this tariff and application of associated rates, terms and conditions is not constrained in any way by the technology used in transmission of the message or the communication transiting or switched on the Company's network. If service is rendered by the Company as described herein, the associated terms and conditions of payment for such services apply.

Issued: May 1, 2017

Resolution No:

Issued by:

Richard E. Ottalagana, Executive Vice President
One PaeTec Plaza, 600 Willowbrook Office Park
Fairport, New York 14450

May 8, 2017

Advice Letter No. 177

SECTION 2 - RULES AND REGULATIONS (Cont'd)

2.1 USE OF FACILITIES AND SERVICES (Cont'd)

2.1.2 Limitations

- A. Service is offered subject to the availability of the necessary facilities and/or equipment and subject to the provisions of this tariff. The Company may decline applications for service to or from a location where the necessary facilities or equipment are not available. The Company may discontinue furnishing service in accordance with the terms of this tariff.
- B. The Company reserves the right to discontinue or limit service when necessitated by conditions beyond its control (examples of these conditions are more fully set forth elsewhere in this tariff), or when service is used in violation of provisions of this tariff or the law.
- C. The Company does not undertake to transmit messages, but offers the use of its service when available, and, as more fully set forth elsewhere in this tariff, shall not be liable for errors in transmission or for failure to establish connections.
- D. The Company reserves the right to discontinue service, limit service, or to impose requirements as required to meet changing regulatory or statutory rules and standards, or when such rules and standards have an adverse material affect on the business or economic feasibility of providing service, as determined by the Company in its reasonable judgment.
- E. The Company reserves the right to refuse an application for service made by a present or former Customer who is indebted to the Company for service previously rendered pursuant to this Tariff until the indebtedness is satisfied.

Issued: May 1, 2017

Resolution No:

Issued by:

Richard E. Ottalagana, Executive Vice President
One PaeTec Plaza, 600 Willowbrook Office Park
Fairport, New York 14450

May 8, 2017

Advice Letter No. 177

SECTION 2 - RULES AND REGULATIONS (Cont'd)

2.1 USE OF FACILITIES AND SERVICES (Cont'd)

2.1.3 Customer-Authorized Use

Any service provided under this Tariff may be resold to or shared (jointly used) with other persons at the Customer's option. The Customer remains solely responsible for all use of service ordered by it or billed to its telephone number(s) pursuant to this Tariff, for determining who is authorized to use its service, and for promptly notifying the Company of any unauthorized use. The Customer may advise its customers that a portion of its service is provided by the Company, but the Customer shall not represent that the Company jointly participates with the Customer in the provision of the service.

2.1.4 Use and Ownership of Equipment

The Company's equipment, apparatus, channels and lines shall be carefully used. Equipment furnished by the Company shall remain its property and shall be returned to the Company whenever requested, within a reasonable period following the request, in good condition (subject to reasonable wear and tear). The Customer is required to reimburse the Company for any loss of, or damage to, the facilities or equipment on the Customer's premises, including loss or damage caused by agents, employees or independent contractors of the Customer through any negligence.

2.1.5 Individual Case Base (ICB) Arrangements

The company may develop a bid in which the regulation, if applicable, rates and charges for the offering under the provisions of this Tariff are developed on the circumstances in each case. ICB arrangements will be summarized in an attachment to this Tariff.

2.1.6 Minimum Use Contracts

The Company may offer services which require a minimum use guarantee ("MUG") wherein the Customer agrees, in writing, to pay the minimum amount per period agreed to upon commencement of service. Customers falling below their MUG will be billed for the minimum amount due per period pursuant to the MUG agreement.

SECTION 2 - RULES AND REGULATIONS (Cont'd)

2.1 USE OF FACILITIES AND SERVICES (Cont'd)

2.1.6 Minimum Use Contracts (Cont'd)

Should the Customer choose to terminate their contract prior to expiration of the term agreed to in the MUG agreement, the Customer will be liable for the minimum usage requirements contained in the contract multiplied by the number of months remaining in the term, unless Customer converts to another Company service with equal or greater term and minimum usage commitments. If no minimum usage requirements are specified in the contract, upon any early termination of Customer's contract, Customer will be liable for their monthly average usage (calculated over the last three full months immediately preceding the date of termination) multiplied by the number of months remaining in the term.

2.2 MINIMUM PERIOD OF SERVICE

The minimum period for which services are provided and for which rates and charges are applicable is one month unless otherwise specified. When a service is discontinued prior to the expiration of the minimum period, charges are applicable, whether the service is used or not.

Issued: May 1, 2017

Resolution No:

Issued by:

Richard E. Ottalagana, Executive Vice President
One PaeTec Plaza, 600 Willowbrook Office Park
Fairport, New York 14450

May 8, 2017

Advice Letter No. 177

SECTION 2 - RULES AND REGULATIONS (Cont'd)

2.3 FLEXIBLE PRICING

2.3.1 General

Flexible Pricing sets minimum and maximum rates that can be charged for access service. The Company may change a specific rate within the range of the established minimum and maximum rates.

2.3.2 Conditions

- A. The Company reserves the right to change prices at any time subject to regulatory requirements by filing a revised Rate Attachment with the Commission.
- B. Customer notification of a rate change shall be made in accordance with Commission regulations. Where there are no regulations, notification will be made in a manner appropriate to the circumstances involved.
- C. A rate shall not be changed unless it has been in effect for at least thirty (30) days.

2.4 PAYMENT FOR SERVICE RENDERED

2.4.1 Service is provided and billed on a monthly basis. Bills are due and payable upon receipt. In the event that the Company incurs fees or expenses, including attorney's fees, collecting, or attempting to collect, any charges owed to the Company, the Company may charge the Customer all such fees and expenses reasonably incurred, including a collection fee on the overdue charges accruing at the rate of 1.5% per month or the highest rate allowed by law, whichever is lower. Collection fees on overdue charges shall begin to accrue when the Account is assigned to an outside collection agency. Such collection fees are separate and distinct from attorney's fees and other costs incurred in collecting charges owed to the Company.

Issued: May 1, 2017

Resolution No:

Issued by:

Richard E. Ottalagana, Executive Vice President
One PaeTec Plaza, 600 Willowbrook Office Park
Fairport, New York 14450

May 8, 2017

Advice Letter No. 177

SECTION 2 - RULES AND REGULATIONS (Cont'd)

2.4 PAYMENT FOR SERVICE RENDERED (Cont'd)

- 2.4.2 The Customer is responsible for payment of all charges for service furnished to the Customer, or the Customer's agents, End Users or customers. All charges due by the Customer are payable to the Company or to the Company's authorized billing agent. Any objections to billed charges must be reported promptly to the Company.
- 2.4.3 The Company reserves the right to assess a charge of \$20.00 whenever a check or draft presented for payment of service is not accepted by the institution upon which it is written. The foregoing shall not limit the Company's right to discontinue service for returned checks or drafts under Section 2.9.1 below.
- 2.4.4 Application of Late Payment Charge
- A. Late payment charges do not apply to final accounts.
 - B. Late payment charges do not apply to government agencies of the State of California. These agencies are required to make payment in accordance with the provisions of California State Law.
 - C. Customer bills are due on the due date specified on the bill. A customer is in default unless payment is made on or before the due date specified on the bill. If payment is not received by the customer's next billing date, a late payment charge of 1.5% will be applied to all amounts previously billed under this Tariff, including arrears and unpaid late payment charges.
 - D. Late payment charges do not apply to those portions (and only those portions) of unpaid balances that are associated with disputed amounts. Undisputed amounts on the same bill are subject to late payment charges if unpaid and carried forward to the next bill.
- 2.4.5 If Company initiates legal proceedings to collect any amount due hereunder and the Company substantially prevails in such proceedings, then the Customer shall pay all reasonable attorneys' fees and costs incurred by the Company in prosecuting such proceedings and any appeals therefrom.

Issued: May 1, 2017

Resolution No:

Issued by:

Richard E. Ottalagana, Executive Vice President
One PaeTec Plaza, 600 Willowbrook Office Park
Fairport, New York 14450

May 8, 2017

Advice Letter No. 177

SECTION 2 - RULES AND REGULATIONS (Cont'd)

2.5 DEPOSITS

- 2.5.1 The Company reserves the right to examine the credit record of the Customer. If the Customer's financial condition is unknown or unacceptable to the Company, the Customer may be required to provide the Company with a security deposit which the Company may apply against overdue charges. The amount of the security deposit shall be equal to two month's estimated usage but may vary with the Customer's credit history and projected usage. The Customer shall be apprised that after one year of service the Account shall be reviewed, and in the event that all amounts due have been paid within the terms and conditions of this tariff, the deposit shall be refunded in full. If subsequent payment or usage patterns change, the Company may request an increase in or re-submission of the security deposit as appropriate. The Company may also require a security deposit before service is restored (along with the payment of overdue charges) from the Customer whose service has been discontinued for nonpayment of overdue charges. Such security deposit may be based on a new credit history (taking into account the discontinuance of service) and estimates of usage.
- 2.5.2 The fact that a security deposit has been made in no way relieves the Customer from the prompt payment of bills upon presentation.
- 2.5.3 If the amount of a deposit is proven to be less than required to meet the requirements specified above, the Customer shall be required to pay an additional deposit upon request.
- 2.5.4 When a deposit is to be returned, the Customer may request that the full amount of the deposit be issued by check. If the Customer requests that the full amount be credited to amounts owed the Company, the Company will apply the deposit to any amount currently owed to the Company, and return any remaining amount of the deposit to the Customer by check.

Issued: May 1, 2017

Resolution No:

Issued by:

Richard E. Ottalagana, Executive Vice President
One PaeTec Plaza, 600 Willowbrook Office Park
Fairport, New York 14450

May 8, 2017

Advice Letter No. 177

SECTION 2 - RULES AND REGULATIONS (Cont'd)

2.6 ADVANCE PAYMENTS

The Company reserves the right to require an advance payment from the Customer instead of or in addition to a security deposit. The advance payment shall be in an amount equal to or less than estimated installation charges plus two months estimated billing.

2.7 DISPUTED BILLS

Provided timely notice has been given in accordance with Section 8.1, in the case of a billing dispute between the Customer and the Company for service furnished to the Customer, which cannot be settled with mutual satisfaction, the Customer may, within 30 days of the date of the bill containing the disputed amount, request, and the Company shall comply with the request, an in-depth investigation and review of the disputed amount. (The undisputed portion and subsequent bills must be paid on a timely basis or service shall be subject to cancellation under Section 2.9 following). The Company shall communicate to the Customer the results of such investigation and review as soon as reasonably possible.

2.8 TAXES AND OTHER SURCHARGES

Customer shall pay all sales, use, gross receipts, excise, access, bypass, or other local, state, and federal taxes, charges, or surcharges, however designated, imposed on or based upon the provision, sale or use of the services (excluding taxes on Company's net income). Such taxes shall be separately stated on the applicable invoice.

Issued: May 1, 2017

Resolution No:

Issued by:

Richard E. Ottalagana, Executive Vice President
One PaeTec Plaza, 600 Willowbrook Office Park
Fairport, New York 14450

May 8, 2017

Advice Letter No. 177

SECTION 2 - RULES AND REGULATIONS (Cont'd)

2.9 INSPECTION, TESTING AND ADJUSTMENT

- 2.9.1 The Company may, upon reasonable notice, make such tests and inspections as may be necessary to determine whether the terms and conditions of this tariff are being complied with in the installation, operation or maintenance of the Customer's or the Company's facilities or equipment. The Company may interrupt service at any time, without penalty or liability, due to the departure from or reasonable suspicion of the departure from any of these terms and conditions.
- 2.9.2 The Customer shall be responsible for making arrangements or obtaining permission for safe and reasonable access for Company employees or agents of the Company to enter the premises of the Customer or any joint user or customer of the Customer at any reasonable hour for the purpose of inspecting, repairing, testing or removing any part of the Company's facilities.
- 2.9.3 Upon reasonable notice, the facilities or equipment provided by the Company shall be made available to the Company for such tests and adjustments as may be necessary for their maintenance in a condition satisfactory to the Company. No interruption allowance shall be granted for the time during which such tests and adjustments are made, unless such interruption exceeds twenty-four hours in length and is requested by the Customer.

Issued: May 1, 2017

Resolution No:

Issued by:

Richard E. Ottalagana, Executive Vice President
One PaeTec Plaza, 600 Willowbrook Office Park
Fairport, New York 14450

May 8, 2017

Advice Letter No. 177

SECTION 2 - RULES AND REGULATIONS (Cont'd)

2.10 SUSPENSION OR TERMINATION OF SERVICE

2.10.1 Suspension or Termination for Nonpayment

- A. In the event that any bill rendered or any deposit required is not paid, the Company may suspend service or terminate service until the bill or the required deposit has been paid. If service is suspended or terminated for nonpayment, the Customer must remit a Connection Charge as well as any payment due and any applicable deposits prior to reconnection.
- B. Suspension or termination shall not be made until:
 - 1. At least 10 days after written notification has been served personally on the Customer, or at least 20 days after written notification has been mailed to the billing address of the Customer or;
 - 2. At least 10 days after the Customer has either signed for or refused a registered letter containing written notification mailed to the billing address of the Customer.
- C. Access service shall not be suspended or terminated for nonpayment on weekends, public holidays, other federal and state holidays proclaimed by the President or the Governor, or on days when the main business office of the Company is not open for business.

Issued: May 1, 2017

Resolution No:

Issued by:

Richard E. Ottalagana, Executive Vice President
One PaeTec Plaza, 600 Willowbrook Office Park
Fairport, New York 14450

May 8, 2017

Advice Letter No. 177

SECTION 2 - RULES AND REGULATIONS (Cont'd)

2.10 SUSPENSION OR TERMINATION OF SERVICE (Cont'd)

2.10.2 Exceptions to Suspension and Termination

Access service shall not be suspended or terminated for:

- A. Nonpayment of bills rendered for charges other than access service or deposits requested in connection with access service;
- B. Nonpayment for service for which a bill has not been rendered;
- C. Nonpayment for service which have not been rendered;
- D. Nonpayment of any billed charge which is in dispute or for the nonpayment of a deposit which is in dispute during the period before a determination of the dispute is made by the Company in accordance with Company's complaint handling procedures. These procedures are in accordance with the Public Utilities Commission Rules and Regulations.
- E. Access service may be suspended or terminated for nonpayment of the undisputed portion of a disputed bill or deposit if the Customer does not pay the undisputed portion after being asked to do so.

Issued: May 1, 2017

Resolution No:

Issued by:

Richard E. Ottalagana, Executive Vice President
One PaeTec Plaza, 600 Willowbrook Office Park
Fairport, New York 14450

May 8, 2017

Advice Letter No. 177

SECTION 2 - RULES AND REGULATIONS (Cont'd)

2.10 SUSPENSION OR TERMINATION OF SERVICE (Cont'd)

2.10.3 Verification of Nonpayment

Access service shall not be suspended or terminated for nonpayment of a bill rendered or a required deposit unless The Company has verified, in a manner approved by the Public Utilities Commission, that payment has not been received at any office of the Company or at any office of an authorized collection agent through the end of the period indicated in the notice.

Issued: May 1, 2017

Resolution No:

Issued by:

Richard E. Ottalagana, Executive Vice President
One PaeTec Plaza, 600 Willowbrook Office Park
Fairport, New York 14450

May 8, 2017

Advice Letter No. 177

SECTION 2 - RULES AND REGULATIONS (Cont'd)

2.10 SUSPENSION OR TERMINATION OF SERVICE (Cont'd)

2.10.4 Termination For Cause Other Than Nonpayment

A. General

The Company, after notice in writing to the Customer and after having given the Customer an appropriate opportunity to respond to such notice, may terminate service and sever the connection(s) from the Customer's premises under the following conditions:

1. in the event of prohibited, unlawful or improper use of the facilities or service, or any other violation by the Customer of the rules and regulations governing the facilities and service furnished, or
2. if, in the judgment of the Company, any use of the facilities or service by the Customer may adversely affect the Company's personnel, plant, property or service. The Company shall have the right to take immediate action, including termination of the service and severing of the connection, without notice to the Customer when injury or damage to telephone personnel, plant, property or service is occurring, or is likely to occur, or
3. in the event of unauthorized use, where the Customer fails to take reasonable steps to prevent the unauthorized use of the facilities or service received from the Company, or
4. in the event that service is connected for a Customer who is indebted to the Company for service or facilities previously furnished, that service may be terminated by the Company unless the Customer satisfies the indebtedness within 20 days after written notification.

Issued: May 1, 2017

Resolution No:

Issued by:

Richard E. Ottalagana, Executive Vice President
One PaeTec Plaza, 600 Willowbrook Office Park
Fairport, New York 14450

May 8, 2017

Advice Letter No. 177

SECTION 2 - RULES AND REGULATIONS (Cont'd)

2.10 SUSPENSION OR TERMINATION OF SERVICE (Cont'd)

2.10.4 Termination For Cause Other Than Nonpayment (cont'd)

B. Prohibited, Unlawful or Improper Use of the Facilities or Service

Prohibited, unlawful or improper use of the facilities or service includes, but is not limited to:

1. The use of facilities or service of the Company without payment of tariff charges;
2. Permitting fraudulent use.

C. Abandonment or Unauthorized Use of Facilities

1. If it is determined that facilities have been abandoned, or are being used by unauthorized persons, or that the Customer has failed to take reasonable steps to prevent unauthorized use, the Company may terminate access service.
2. In the event that access service is terminated for abandonment of facilities or unauthorized use and service is subsequently restored to the same Customer at the same location:
 - a. no charge shall apply for the period during which service had been terminated, and
 - b. Reconnection charges will apply when service is restored. However, no charge shall be made for reconnection if the service was terminated due to an error on the part of the Company.

Issued: May 1, 2017

Resolution No:

Issued by:

Richard E. Ottalagana, Executive Vice President
One PaeTec Plaza, 600 Willowbrook Office Park
Fairport, New York 14450

May 8, 2017

Advice Letter No. 177

SECTION 2 - RULES AND REGULATIONS (Cont'd)

2.10 SUSPENSION OR TERMINATION OF SERVICE (Cont'd)

2.10.4 Termination For Cause Other Than Nonpayment (cont'd)

D. Change in the Company's Ability to Secure Access

Any change in the Company's ability (a) to secure and retain suitable facilities and rights for the construction and maintenance of the necessary circuits and equipment or (b) to secure and retain suitable space for its plant and facilities in the building where service is provided to the Customer may require termination of a Customer's service until such time as new arrangements can be made. No charges will be assessed the Customer while service is terminated, and no connection charges will apply when the service is restored.

Issued: May 1, 2017

Resolution No:

Issued by:

Richard E. Ottalagana, Executive Vice President
One PaeTec Plaza, 600 Willowbrook Office Park
Fairport, New York 14450

May 8, 2017

Advice Letter No. 177

SECTION 2 - RULES AND REGULATIONS (Cont'd)

2.10 SUSPENSION OR TERMINATION OF SERVICE (Cont'd)

2.10.5 Emergency Termination of Service

The Company will immediately terminate the service of any Customer, on request, when the Customer has reasonable belief that the service is being used by an unauthorized person or persons. The Company may require that the request be submitted in writing as a follow-up to a request made by telephone.

2.10.6 Voluntary Termination By Customer

- A. A Customer wishing to terminate any access service obtained from the Company must do so in accordance with the following procedures. These procedures apply regardless of whether the service to be terminated was purchased through submission of an explicit order or through use by the Customer of the access service, as set forth in Section 2.11.11 of this Tariff. Any purported voluntary termination by a Customer of the Company's access service shall be ineffective unless and until the procedures in this Section have been followed.
- B. The Customer must send to the Company, by certified or traceable mail services, written notice of any voluntary termination of access service.
1. Such notice shall be clearly titled "Voluntary termination of Access Service," and shall include at a minimum the following information: effective date of the termination, type and jurisdiction of the access services to be terminated, applicable originating or terminating NPA-NXX, carrier identification code, applicable serving wire center information by vertical and horizontal coordinates and the physical address of the Company serving wire center performing switching functions for the services in questions.

Issued: May 1, 2017

Resolution No:

Issued by:

Richard E. Ottalagana, Executive Vice President
One PaeTec Plaza, 600 Willowbrook Office Park
Fairport, New York 14450

May 8, 2017

Advice Letter No. 177

SECTION 2 - RULES AND REGULATIONS (Cont'd)

2.10 SUSPENSION OR TERMINATION OF SERVICE (Cont'd)

2.10.6 Voluntary Termination By Customer (Cont'd)

2. The notice must be received by the Company at least ninety (90) days in advance of the desired termination date. In the event any of the required information is missing or incorrect, the Company will so advise the Customer in writing. Any revised or corrected termination notice must also be submitted on ninety (90) days notice.
- C. The Company will review any such termination notice in a timely manner and will advise the Customer , with respect to each affected access service, whether the service can be blocked by the Company, or whether it must be blocked by the Customer.
1. For access services which can be blocked by the Company, the Company will assess the cost of blocking and termination services per request. Blocking and termination services are subject to the hourly rate specified per technician repair service in the Company's local exchange tariffs as published in the state in which the access services are originated. In addition, blocking and termination services are subject to a one time non-recurring termination and blocking charge as specified in the rate schedule included in this tariff. The termination and blocking charge will be individually set per requesting Customer and will be based on cost factors necessary for the Company to perform the services rendered.
 2. After the Company determines the applicable charges for termination and blocking, the Company shall advise the Customer of the charge(s) that will apply. All blocking and terminating charges must be paid in full at least thirty (30) days in advance of the planned termination date.
 3. The Company may at its option route blocked calls to a live or recorded announcement informing end users that the call cannot be completed as dialed because the Customer has voluntarily ceased accepting access services from the Company, and suggesting alternative means for completing the call.

Issued: May 1, 2017

Resolution No:

Issued by:

Richard E. Ottalagana, Executive Vice President
One PaeTec Plaza, 600 Willowbrook Office Park
Fairport, New York 14450

May 8, 2017

Advice Letter No. 177

SECTION 2 - RULES AND REGULATIONS (Cont'd)

2.10 SUSPENSION OR TERMINATION OF SERVICE (Cont'd)

2.10.6 Voluntary Termination By Customer (Cont'd)

4. For access services which must be blocked by the Customer, the Customer shall be solely responsible for blocking or terminating such services as of the termination date specified in the Customer's notice, at the Customer's sole expense. The Customer shall be responsible for informing any affected end users that their service may be disrupted as a result of the Customer's blocking activity.

- D. All rates and charges applicable under the Tariff shall continue to apply to any Company access service(s) used by the Customer after the termination date, except to the extent that the Company has undertaken to block such service(s) and the Customer has timely paid all applicable termination and blocking charges.

2.11 OBLIGATIONS OF THE CUSTOMER

2.11.1 Damages

The Customer shall reimburse the Company for damages to Company facilities utilized to provide services under this tariff caused by the negligence or willful act of the Customer, or resulting from improper use of the Company's facilities, or due to malfunction of any facilities or equipment provided by other than the Company, except that no Customer shall be liable for another Customer's actions.

2.11.2 Ownership of Facilities

Facilities utilized by the Company to provide service under the provisions of this tariff shall remain the property of the Company. Such facilities shall be returned to the Company by the Customer, whenever requested, within a reasonable period following the request in as good condition as reasonable wear permits.

SECTION 2 - RULES AND REGULATIONS (Cont'd)

2.11 OBLIGATIONS OF THE CUSTOMER (Cont'd)

2.11.3 Equipment Space and Power

The Customer shall furnish to the Company, at no charge, equipment space and electrical power required by the Company to provide services under this tariff at the points of termination of such services. The selection of AC or DC power shall be mutually agreed to by the Customer and the Company. The Customer shall make necessary arrangements in order that the Company will have access to such spaces at reasonable times for installation, testing, repair, maintenance or removal of Company service. Customer shall provide a safe place to work which complies with all laws and regulations along the rights-of-way and in the equipment spaces which it is responsible for obtaining, and at which Company authorized personnel, employees, or agents may be installing, inspecting, maintaining, replacing, repairing or removing facilities and equipment.

Customer shall arrange access to any of the rights-of-way, conduit, and equipment space which it is responsible for obtaining at any time so that Company's authorized personnel, employees, or agents may install, repair, maintain, inspect, replace or remove any and all facilities and associated equipment provided by Company. Access to such sites shall be made available at a time mutually agreeable to Customer and Company. Customer acknowledges that, when repair work is required to restore services after interruption, it may be necessary to provide access on a twenty-four hour, seven day a week basis. Company shall also have the right to obtain access to the cable installed in Customer provided conduit at any splice or junction box. No credit allowance will be made for the period during which service is interrupted for such purposes.

Customer shall be responsible for obtaining and continuing in effect all approvals, consents, authorizations, licenses, and permits as may be required to permit Customer to comply with its obligations hereunder.

Customer use of any service obtained from other service providers by the Company and resold to Customer shall also be subject to any applicable restrictions in the underlying providers' publicly available tariffs.

Issued: May 1, 2017

Resolution No:

Issued by:

Richard E. Ottalagana, Executive Vice President
One PaeTec Plaza, 600 Willowbrook Office Park
Fairport, New York 14450

May 8, 2017

Advice Letter No. 177

SECTION 2 - RULES AND REGULATIONS (Cont'd)

2.11 OBLIGATIONS OF THE CUSTOMER (Cont'd)

2.11.4 Testing

The services provided under this tariff shall be made available to the Company at mutually agreed upon times in order to permit the Company to test, adjust and maintain the services in satisfactory operating condition. No credit will be allowed for any interruption during such tests and adjustments.

2.11.5 Design of Customer Services

The Customer shall be responsible for its own expense for the overall design of its services and for any redesigning or rearrangements of its services which may be required because of changes in facilities, operations or procedures of the Company, minimum protection criteria or operating or maintenance characteristics of the facilities.

2.11.6 Network Contingency Coordination

The Customer shall, in cooperation with the Company, coordinate in planning the actions to be taken to maintain maximum network capability following natural or man-made disasters which affect telecommunications service.

SECTION 2 - RULES AND REGULATIONS (Cont'd)

2.11 OBLIGATIONS OF THE CUSTOMER (Cont'd)

2.11.7 Jurisdictional Reports

Where possible, the Company will determine the jurisdiction of both originating and terminating calls from the call detail records generated via the switched network, and bill usage according to such determination. A call that enters the Customer's or Other Network Provider's ("ONP") network in a state different from the state in which the called station is located will be classified as interstate. A call that enters the Customer's or ONP's network at a point within the same state where the called station is located will be classified as intrastate. In these situations, the call is compensated according to the Company's switched access service rates, terms and conditions. A call that enters the Company network at a point within the same local calling area where the called station is located, as defined by the local exchange tariff of the incumbent LEC in whose territory the call completes, will be classified as local and subject to reciprocal compensation as described in Section 7.

In those cases where it is not possible for the Company to determine the jurisdiction of the call from the call detail, the Customer or ONP may provide the Company with a Percent Interstate Use (PIU) in order for the Company to properly jurisdictionalize intrastate from interstate services. The Customer or ONP may also provide a percent local use (PLU) to be applied to intrastate usage in order to separate the local traffic component. The percent, which should be represented as a whole number, is determined by taking the total interstate or local usage and dividing by the total minutes of use. For example, a Customer or ONP may have 100 total minutes for a bill period. In a situation where the Company might not be able to determine the jurisdiction of those minutes, the Customer or ONP would submit its PIU and PLU. If 90 MOUs were interstate, the PIU would be 90% and the customer would be invoiced for 90 MOUs at the interstate rate as tariffed. The remaining 10 MOUs are assumed to be intrastate if the Company cannot determine jurisdiction unless the Customer or ONP submits a PLU. If 9 minutes were local, the PLU would be 9% and the customer would be invoiced for 9 MOUs at the reciprocal compensation rate and the remaining 1 MOU at the intrastate switched access rate. The Customer or ONP may update the jurisdictional percentages reported to the Company on the First of January, First of April, First of July, and First of October. Reports should be received no later than the 20th of each month. Reports will be used on a go-forward basis, and will be in effect until the Customer submits a revised report. Customers beginning service in the middle of a quarter may submit a jurisdictional report at the onset of service.

Issued: May 1, 2017

Resolution No:

Issued by:

Richard E. Ottalagana, Executive Vice President
One PaeTec Plaza, 600 Willowbrook Office Park
Fairport, New York 14450

May 8, 2017

Advice Letter No. 177

SECTION 2 – RULES AND REGULATIONS (Cont'd)

2.11 OBLIGATIONS OF THE CUSTOMER (Cont'd)

2.11.7 Jurisdictional Reports (Cont'd)

In the absence of a Customer-or ONP provided percent interstate use or percent local use, the following percentages will be used:

900 traffic: 100% PIU
700 traffic: 100% PIU
Local traffic: 0% PIU, 0% PLU
ISP traffic: 0% PIU, 0% PLU
All other: percent determined by measurable network usage.

The percent interstate use factor will be used by the Company to determine interstate and intrastate rates and charges where the Company cannot itself determine the jurisdiction of the call transiting its network. If the Customer does not provide a percent interstate use factor as provided in this section, the Company will apply a default PIU factor of fifty percent (50%) and assess the remaining minutes/facilities under the terms of the applicable state access tariff.

No pro-rating or back-billing will be done based on the report. The Company may require call detail records to substantiate projected interstate usage provided to the Company. In the event that the required jurisdictional report is not provided, the Company recorded or estimated percentage of interstate usage will be applied to the bill.

The Company reserves the right to verify the percents on the jurisdictional reports by examination of the underlying data. The Company will submit a request for verification in writing to the Customer or ONP. Such a request will occur no more than once a year. Once the request is received, the Customer will have 30 days to supply or otherwise make available the data to the Company.

The Company may request this detailed information annually. If the audit results represent a substantial deviation from the Customer's or ONP's previously reported PIU/PLU for the period upon which the audit was based, the call detail records may be requested more than once annually.

SECTION 2 - RULES AND REGULATIONS (Cont'd)

2.11 OBLIGATIONS OF THE CUSTOMER (Cont'd)

2.11.8 Mixed Interstate and Intrastate Access Service

When mixed interstate and intrastate Access Service is provided, all charges, including nonrecurring charges, usage charges, and optional features, will be prorated between interstate and intrastate. The percentage provided in the reports as set forth in 2.10.7 will serve as the basis for prorating the charges. The percentage of an Access Service to be charged as intrastate is applied in the following manner:

- A. For nonrecurring chargeable rate elements, multiply the percent intrastate use times the quantity of chargeable elements times the state tariff rate per element.
- B. For usage sensitive chargeable rate elements, multiply the percent intrastate use times actual use (measure or Company assumed average use) times the stated rate.

2.11.9 Measurement of Access Minutes

Customer traffic to end offices will be measured (recorded or assumed) by the Company at end office switches or access tandem switches. Originating and terminating calls will be measured or imputed to determine the basis for computing chargeable access minutes.

With Multifrequency Address Signaling, usage measurement begins when the originating entry switch receives the acknowledgment wink supervisory signal forwarded from the Customer's point of termination. For originating calls with SS7, usage measurement begins when either the Exit Message (EXM) or the Address Complete Message (ACM) is received.

The measurement of originating call usage ends when the entry switch receives disconnect supervision from either the originating end user's end office, indicating the originating end user has disconnected, or the customer's point of termination, whichever is recognized first by the entry switch.

Issued: May 1, 2017

Resolution No:

Issued by:

Richard E. Ottalagana, Executive Vice President
One PaeTec Plaza, 600 Willowbrook Office Park
Fairport, New York 14450

May 8, 2017

Advice Letter No. 177

SECTION 2 - RULES AND REGULATIONS (Cont'd)

2.11 OBLIGATIONS OF THE CUSTOMER (Cont'd)

2.11.9 Measurement of Access Minutes

For terminating calls, the measurement of access minutes begins when the terminating entry switch receives answer supervision from the terminating end user's end office, indicating the terminating end user has answered.

The measurement of terminating call usage ends when the terminating entry switch receives disconnect supervision from either the terminating end user's office, indicating the terminating end user has disconnected, or the customer's point of termination, whichever is recognized first by the entry switch.

2.11.10 Network Congestion

When a Customer offers service for which a substantial call volume is expected during a short period of time, the Customer must notify the Company at least 48 hours in advance of each peak period. Notification should include the nature, time, duration, and frequency of the event, an estimated call volume, and the telephone number(s) to be used. On the basis of the information provided, the Company may invoke network management controls to reduce the probability of excessive network congestion. The Company will work cooperatively with the Customer to determine the appropriate level of such controls.

2.11.11 Purchase of Service

Should a Customer use the Company's access service, regardless of whether the Customer has affirmatively requested service or has an executed service order, the Customer will be subject to the obligations, rates, and charges as set forth in this Tariff.

SECTION 2 - RULES AND REGULATIONS (Cont'd)

2.11 OBLIGATIONS OF THE CUSTOMER (Cont'd)

2.11.12 In certain cases the Company may be required to utilize its network to complete intraLATA toll free traffic programmed for carrier identification code (CIC) 110, which unlike other CICs, does not sufficiently identify a particular carrier that the Company may bill for the access services provided. The Company will perform the toll free database query and route this traffic to the terminating number via its intraLATA interconnection facilities with incumbent or other local exchange carriers in accordance with standard industry practices and information received from the national SMS/800 database. Unless otherwise specified in individual contracts (e.g., interconnection agreements), the carrier or provider to whom the terminating telephone number is assigned by the Local Exchange Routing Guide (LERG) or, if applicable, to whom that number has been ported, shall be deemed to be the Customer of the Company exchange access services which are provided for the switching and transport of any intraLATA toll free CIC 110 calls routed to that number. All toll free CIC 110 calls switched and transported by the Company shall be classified as jurisdictionally intrastate calls. As the Customer, the terminating local provider is responsible for the query charges and all switching and transport charges as specified herein.

All other toll free traffic determined by query to be associated with a carrier/responsible organization with a CIC other than 110 shall be routed and rated per the exchange access rules in other sections of this tariff or PAETEC Communications, Inc.'s FCC Tariff No. 3.

Issued: May 1, 2017

Resolution No:

Issued by:

Richard E. Ottalagana, Executive Vice President
One PaeTec Plaza, 600 Willowbrook Office Park
Fairport, New York 14450

May 8, 2017

Advice Letter No. 177

SECTION 2 - RULES AND REGULATIONS (Cont'd)

2.11 OBLIGATIONS OF THE CUSTOMER (Cont'd)

2.11.13 IDENTIFICATION AND RATING OF VOIP-PSTN TRAFFIC

(A) Scope

- (1) VoIP-PSTN traffic is defined as traffic exchanged over the public switched telephone network ("PSTN") facilities that originates and/or terminates in Internet protocol ("IP") format. This section governs the identification of toll VoIP-PSTN ("toll VoIP") traffic that in the absence of an interconnection agreement will be subject to interstate switched access rates in accordance with the Federal Communications Commission Report and Order in WC Docket Nos. 10-90, etc., FCC No. 11-161 released (Nov. 18, 2011) ("FCC Order") as it may hereinafter be amended or clarified. Specifically, this section establishes the method of distinguishing toll VoIP traffic from the customer's total intrastate access traffic, so that toll VoIP traffic will be billed in accordance with the FCC Order.
- (2) This section will be applied to the billing of switched access charges to a customer that is a local exchange carrier only to the extent that the customer has also implemented billing of interstate access charges for VoIP-PSTN Traffic in accordance with the FCC Order.

(B) Rating of toll VoIP-PSTN traffic

The Telephone Company will bill toll VoIP-PSTN traffic which it identifies in accordance with this tariff section at rates equal to the Telephone Company's applicable tariffed interstate switched access rates.

(C) Calculation and Application of Percent-VoIP-Usage Factor

The Telephone Company will determine the number of toll VoIP traffic minutes of use ("MOU") to which it will apply its interstate rates under subsection (B), above, by applying an originating Percent VoIP Usage ("OPVU") factor to the total intrastate access MOU originated by a Telephone Company end user and delivered to the customer and by applying a terminating PVU ("TPVU") factor to the total intrastate access MOU terminated by a customer to the Telephone Company's end user. The OPVU and TPVU will be derived and applied as follows:

SECTION 2 - RULES AND REGULATIONS (Cont'd)

2.11 OBLIGATIONS OF THE CUSTOMER (Cont'd)

2.11.13 IDENTIFICATION AND RATING OF VOIP-PSTN TRAFFIC (Cont'd)

- (1) The customer will calculate and furnish to the Telephone Company an OPVU factor, along with supporting documentation, representing the whole number percentage of the customer's total originating intrastate access MOU that the customer receives from the Telephone Company in the State that is originated by the Telephone Company in IP format.
- (2) The customer will calculate and furnish to the Telephone Company a TPVU factor, along with supporting documentation, representing the whole number percentage of the customer's total terminating intrastate access MOU that the customer exchanges with the Telephone Company in the State that is sent to the Telephone Company and originated in IP format.
- (3) The OPVU, TPVU and supporting documentation shall be based on information that is verifiable by the Telephone Company including but not limited to the number of the customer's retail VoIP subscriptions in the state (*e.g.*, as reported on FCC Form 477), traffic studies, actual call detail, or other relevant and verifiable information. The customer shall not modify its reported PIU factor to account for VoIP-PSTN traffic.
- (4) After the Telephone Company verifies the OPVU and TPVU provided by the customer the Telephone Company will apply the OPVU and TPVU factors to the associated intrastate access MOU as indicated in Sections (D) and/or (E) below.

In the event that the Telephone Company can not verify the customer's OPVU and/or TPVU, the Telephone Company will request additional information to support the OPVU and/or TPVU, during this time no changes will be made to the existing OPVU and/or TPVU. The customer shall supply the requested additional information within 15 days of the Telephone Company's request or no changes will be made to the existing OPVU and/or TPVU. If after review of the additional information, the customer and Telephone Company establish a revised and mutually agreed upon OPVU and/or TPVU factor, the Telephone Company will begin using the new factor with the next bill period.

Issued: May 1, 2017

Resolution No:

Issued by:

Richard E. Ottalagana, Executive Vice President
One PaeTec Plaza, 600 Willowbrook Office Park
Fairport, New York 14450

May 8, 2017

Advice Letter No. 177

SECTION 2 - RULES AND REGULATIONS (Cont'd)

2.11 OBLIGATIONS OF THE CUSTOMER (Cont'd)

2.11.13 IDENTIFICATION AND RATING OF VOIP-PSTN TRAFFIC (Cont'd)

If the dispute is unresolved the customer may request that verification audits be conducted by an independent auditor, at customer's sole expense. During the audit, the most recent undisputed OPVU and/or TPVU factor will be used by the Telephone Company.

- (5) In the absence of an interconnection agreement, at no time will the Telephone Company allow an OPVU or TPVU factor greater than the applicable State percentage as identified in Paragraph 963 of the FCC Order.

(D) Initial OPVU and TPVU Factor

In calculating the initial OPVU and TPVU factor(s), the Telephone Company will take the factor(s) provided by the customer into account retroactively to January 1, 2012, *provided that* the customer provides the factor(s) and supporting documentation, as specified in subsection (C) above to the Telephone Company no later than 15 days after the effective date of this tariff. If the customer does not furnish the Telephone Company with an OPVU and/or TPVU factor pursuant to the preceding subsection (C), the initial factor will be zero.

(E) OPVU and TPVU Factor Updates

The customer may update the OPVU and/or TPVU factor(s) semi-annually using the method set forth in subsection (C), above. If the customer chooses to submit such updates, it shall forward to the Telephone Company, no later than 15 days after the first day of January and/or July of each year, a revised OPVU and/or TPVU factor and supporting documentation based on data for the prior three months, ending the last day of December and/or June, respectively. Once verified by the Telephone Company the revised OPVU and/or TPVU factor will apply prospectively and serve as the basis for billing until superseded by a new verified factor.

SECTION 2 - RULES AND REGULATIONS (Cont'd)

2.12 AUTOMATIC NUMBER IDENTIFICATION

2.12.1 General

This option provides the automatic transmission of a seven or ten digit number and information digits to the Customer's premises for calls originating in the LATA, to identify the calling station. The ANI feature, which is a software function, will be associated on a call-by-call basis with (1) all individual transmission paths in a trunk group routed directly between an end office and a Customer's premises or, where technically feasible, with (2) all individual transmission paths in a trunk group between an access tandem and a Customer's premises.

Additional ANI information digits are available with Feature Group D only. These information digits will be transmitted as agreed to by the Customer and the Company.

2.12.2 Up to 7 Digit Outpulsing of Access Digits to Customer

This Option provides for the end office capability of providing up to 7 digits of the uniform access code (950-10XX) to the Customer premises. The Customer can request that only some of the digits in the access code be forwarded. The access code digits would be provided to the Customer premises location using multifrequency signaling, and transmission of the digits would precede the forwarding of ANI if that feature were provided. It is available with Feature Group B.

SECTION 2 - RULES AND REGULATIONS (Cont'd)

2.12 AUTOMATIC NUMBER IDENTIFICATION (Cont'd)

2.12.3 Regulations

The Company will provide Automatic Number Identification (ANI) associated with an intrastate service, by tariff, to any entity (ANI recipient), only under the following terms and conditions:

- A. The ANI recipient or its designated billing agent may use or transmit ANI information to third parties for billing and collection, routing, screening, ensuring network performance, and completion of a telephone subscriber's call or transaction, or for performing a service directly related to the telephone subscriber's original call or transaction, or for performing a service directly related to the telephone subscriber's original call or transaction.
- B. The ANI recipient may offer to any telephone subscriber with whom the ANI recipient has an established Customer relationship, a product or service that is directly related to products or service previously purchased by the telephone subscriber from the ANI recipient.
- C. The ANI recipient or its designated billing agent is prohibited from utilizing ANI information to establish marketing lists or to conduct outgoing marketing calls, except as permitted by the preceding paragraph, unless the ANI recipient obtains the prior written consent of the telephone subscriber permitting the use of ANI information for such purposes. The foregoing provisions notwithstanding, no ANI recipient or its designated billing agent may utilize ANI information if prohibited elsewhere by law.

Issued: May 1, 2017

Resolution No:

Issued by:

Richard E. Ottalagana, Executive Vice President
One PaeTec Plaza, 600 Willowbrook Office Park
Fairport, New York 14450

May 8, 2017

Advice Letter No. 177

SECTION 2 - RULES AND REGULATIONS (Cont'd)

2.12 AUTOMATIC NUMBER IDENTIFICATION (Cont'd)

2.12.3 Regulations (Cont'd)

- D. The ANI recipient or its designated billing agent is prohibited from reselling, or otherwise disclosing ANI information to any other third party for any use other than those listed in Provision A, unless the ANI recipient obtains the prior written consent of the subscriber permitting such resale or disclosure.
- E. Violation of any of the foregoing terms and conditions by any ANI recipient other than a Telephone Corporation shall result, after a determination through the Commission's complaint process, in suspension of the transmission of ANI by the Company until such time as the Commission receives written confirmation from the ANI recipient that the violations have ceased or have been corrected. If the Commission determines that there have been three or more separate violations in a 24 month period, delivery of ANI to the offending party shall be terminated under terms and conditions determined by the Commission.
- F. The ten digit ANI telephone number is only available with Feature Group D. The ten digit ANI telephone number consists of the Numbering Plan Area (NPA) plus the seven digit ANI telephone number. The ten digit ANI telephone number will be transmitted on all calls except in the case of ANI failure, in which case only the NPA will be transmitted (in addition to the information digit described below).

Issued: May 1, 2017

Resolution No:

Issued by:

Richard E. Ottalagana, Executive Vice President
One PaeTec Plaza, 600 Willowbrook Office Park
Fairport, New York 14450

May 8, 2017

Advice Letter No. 177

SECTION 2 - RULES AND REGULATIONS (Cont'd)

2.12 AUTOMATIC NUMBER IDENTIFICATION (Cont'd)

G. Where ANI cannot be provided, information digits will be provided to the Customer.

The information digits identify: (1) telephone number is the station billing number - no special treatment required, (2) ANI failure has occurred in the end office switch which prevents identification of calling telephone number - must be obtained by operator or in some other manner. The ANI telephone number is the listed telephone number of the Customer and is not the telephone number of the calling party.

2.12.4 Terms and Conditions

Violation of any of the foregoing terms and conditions by a Telephone Corporation may result in Commission prosecution of penalty and enforcement proceedings pursuant to the Public Utilities Law of the State of California.

2.13 DETERMINATION OF MILEAGE

Service for which rates are mileage sensitive are rated on the airline distance between the Company's switch location and Customer-designated premises or the end office of the Customer-designated premises.

Issued: May 1, 2017

Resolution No:

Issued by:

Richard E. Ottalagana, Executive Vice President
One PaeTec Plaza, 600 Willowbrook Office Park
Fairport, New York 14450

May 8, 2017

Advice Letter No. 177

SECTION 3 - SWITCHED ACCESS SERVICE

3.1 GENERAL

Switched Access Service, which is available to Customers for their use in furnishing their services to End Users, provides a two-point electrical communications path between a Customer's premises and an End User's premises. It provides for the use of common terminating, switching and trunking facilities, and for the use of common subscriber plant of the Company. Switched Access Service provides for the ability to originate calls from an End User's premises to a Customer's premises in the LATA where it is provided.

The application of rates for Switched Access Service is described in Sections 3.5 and 3.6 following. Rates and charges for services other than Switched Access Service, e.g., a Customer interLATA toll message service, may also be applicable when Switched Access Service is used in conjunction with these other services.

3.2 RATE CATEGORIES

There are three rate categories which apply to Switched Access Service:

- Network Switching
- Transport Service
- End User and Common Line - see Section 5 of this tariff

Issued: May 1, 2017

Resolution No:

Issued by:

Richard E. Ottalagana, Executive Vice President
One PaeTec Plaza, 600 Willowbrook Office Park
Fairport, New York 14450

May 8, 2017

Advice Letter No. 177

SECTION 3 - SWITCHED ACCESS SERVICE (Cont'd)

3.2 RATE CATEGORIES (Cont'd)

3.2.1 Network Switching

Network Switching provides for the use of Company switching equipment and related network to originate or terminate an access minute of use of any type. It applies to the establishment and release of connections on a per call basis between two or more circuits, communications systems, alternative switches or services. The Network Switch Charge is assessed on a per minute and per call basis

Where switches are appropriately equipped, international dialing may be provided. International dialing provides the capability of switching international calls with service prefix and address codes having more digits than are capable of being switched through a standard equipped end office.

3.2.1.1 Shared Switching Trunk Port includes common port usage access separate from shared trunk side termination arrangements

3.2.2 Transport Service

Transport Service provides for the transmission of calls between the Customer designated premises and the end office switch(es) where the Customer traffic is switched to originate or terminate the Customer's communication. Transport Service is a two-way voice frequency transmission path composed of facilities determined by the Company. The two-way voice frequency transmission path permits the transport of calls in the originating direction (from the Customer designated premise to the end office switch), but not simultaneously. The voice frequency transmission path may be comprised of any form or configuration of plant capable of and typically used in the telecommunications industry for the transmission of voice and associated telephone signals.

Customers who choose Direct Access directly connect with the Company's office(s). In this case, the Customer is responsible for providing its own facility(s) to the Company office(s), and will be charged Port Charges. The Port Charges will consist of a non-recurring connection charge and a recurring monthly rental charge. The Port can be furnished on a DS0 or DS1 basis.

SECTION 3 - SWITCHED ACCESS SERVICE (Cont'd)

3.2.2 Transport Service (Cont'd)

Where the Company utilizes such ports for two-way, jointly provided meet point facilities between its switches and the switching platforms of other carriers or providers (e.g., ILEC tandem switches) and where the other carrier/provider requires payment for dedicated or switched monthly recurring or other flat-rated charges for port/facilities for those same two-way, jointly provided meet point facilities, the Company will invoice that carrier/provider the Company's comparable transport services port charges as detailed herein and at the rates in the rate schedule attached.

Customers who choose Standard Access connect with the Company's office(s) through another LEC's tandem switch. Transport Service rates are made up of a Transport Termination rate which is assessed on a per transmission path per access minute basis, and a Transport Mileage rate assessed on a per mile per access minute basis. The Transport Termination rate provides for the communication frequency transmission path at the Company switch and includes the Transport Service portion of switching and circuit equipment. The Transport Mileage rate applies to transmission facilities provided by the Company between the Company's switch and a remote switching facility. Services are divided into three (3) pricing zones. The pricing zone for each serving wire center is identified in the NECA Tariff F.C.C.

No. 4. Standard Access calls are also assessed an Interconnection charge per minute to provide for additional handling costs.

For purposes of determining Transport Mileage measurement, distance will be measured from the wire center that normally serves the customer designated premises to the switch(es), which may be a Remote Switching Module(s).

Where transmission facilities permit, the individual transmission path between the Customer's designated premises and the first point of switching may at the option of the Customer be provided with the following optional features at no charge:

- Supervisory Signaling
- Customer Specified Entry Switch Receive Level
- Customer Specification of Transport Termination

SECTION 3 - SWITCHED ACCESS SERVICE (Cont'd)

3.3 OBLIGATIONS OF THE COMPANY

The Company has certain obligations pertaining only to the provision of Switched Access Service. These obligations are as follows:

3.3.1 Network Management

The Company will administer its network to provide acceptable service levels to all telecommunications users of the Company's network services. Generally, service levels are considered acceptable only when both End Users and Customers are able to establish connections with little or no delay encountered within the Company's network. The Company maintains the right to apply protective controls, i.e., those actions, such as call gapping, which selectively cancel the completion of any traffic carried over its network, including that associated with a Customer's Switched Access Service. Generally, such protective measures would only be taken as a result of occurrences such as a failure or overload of Company or customer facilities, natural disasters, mass calling or national security demands.

Issued: May 1, 2017

Resolution No:

Issued by:

Richard E. Ottalagana, Executive Vice President
One PaeTec Plaza, 600 Willowbrook Office Park
Fairport, New York 14450

May 8, 2017

Advice Letter No. 177

SECTION 3 - SWITCHED ACCESS SERVICE (Cont'd)

3.3 OBLIGATIONS OF THE COMPANY, (Cont'd)

3.3.2 Design and Traffic Routing of Switched Access Service

The Company shall design and determine the routing of Switched Access Service, including the selection of the first point of switching and the selection of facilities from the interface to any switching point and to the switch where busy hour minutes of capacity are ordered. The Company shall also decide if capacity is to be provided by originating only, terminating only, or two-way trunk groups. Finally, the Company will decide whether trunk side access will be provided through the use of two-wire or four-wire trunk terminating equipment. Selection of facilities and equipment and traffic routing of the service are based on standard engineering methods, available facilities and equipment and the Company's traffic routing plans. If the Customer desires different routing or directionality than that determined by the Company, the Company will work cooperatively with the Customer in determining (1) whether the service is to be routed directly to a switch and (2) the directionality of the service.

Issued: May 1, 2017

Resolution No:

Issued by:

Richard E. Ottalagana, Executive Vice President
One PaeTec Plaza, 600 Willowbrook Office Park
Fairport, New York 14450

May 8, 2017

Advice Letter No. 177

SECTION 3 - SWITCHED ACCESS SERVICE (Cont'd)

3.3 OBLIGATIONS OF THE COMPANY, (Cont'd)

3.3.3 Provision of Service Performance Data

Subject to availability, end-to-end service performance data available to the Company through its own service evaluation routines, may also be made available to the Customer based on previously arranged intervals and format. The data provides information on overall end-to-end call completion and non-completion performance e.g., Customer equipment blockage, failure results and transmission performance. The data does not include service performance data which is provided under other tariff sections, e.g., testing service results. If data is to be provided in other than paper format, the charges for such exchange will be determined on an individual case basis.

3.3.4 Trunk Group Measurements Reports

Subject to availability, the Company will make available trunk group data in the form of usage in CCS, peg count and overflow to the Customer based on previously agreed to intervals.

SECTION 3 - SWITCHED ACCESS SERVICE (Cont'd)

3.4 OBLIGATIONS OF THE CUSTOMER

The Customer has certain specific obligations pertaining to the use of Switched Access Service. These obligations are as follows:

3.4.1 Report Requirements

Customers are responsible for providing the following reports to the Company, when applicable.

A. Jurisdictional Reports

When a Customer orders Switched Access Service for both interstate and intrastate use, the Customer is responsible for providing reports as set forth in Section 2.11.7 preceding. Charges will be apportioned in accordance with those reports.

B. Code Screening Reports

When a Customer orders service call routing, trunk access limitation or call gapping arrangements, it must report the number of trunks and/or the appropriate codes to be instituted in each end office or access tandem switch, for each of the arrangements ordered.

The Company will administer its network in such a manner that the impact of traffic surges due to peaked 900 Access Service traffic on other access service traffic is minimized. Network management controls as defined in Section 3.3.1 may be implemented at the Company option to ensure acceptable service levels

Issued: May 1, 2017

Resolution No:

Issued by:

Richard E. Ottalagana, Executive Vice President
One PaeTec Plaza, 600 Willowbrook Office Park
Fairport, New York 14450

May 8, 2017

Advice Letter No. 177

SECTION 3 - SWITCHED ACCESS SERVICE (Cont'd)

3.4 OBLIGATIONS OF THE CUSTOMER (Cont'd)

3.4.2 On and Off-Hook Supervision

The Customer facilities shall provide the necessary on and off-hook supervision for accurate timing of calls.

3.4.3 Trunk Group Measurements Reports

With the agreement of the Customer, trunk group data in the form of usage in CCS, peg count and overflow for its end of all access trunk groups, where technologically feasible, will be made available to the Company. The data will be used to monitor trunk group utilization and service performance and will be based on previously arranged intervals and format.

Issued: May 1, 2017

Resolution No:

Issued by:

Richard E. Ottalagana, Executive Vice President
One PaeTec Plaza, 600 Willowbrook Office Park
Fairport, New York 14450

May 8, 2017

Advice Letter No. 177

SECTION 3 - SWITCHED ACCESS SERVICE (Cont'd)

3.5 RATE REGULATIONS

This section contains the specific regulations governing the rates and charges that apply for Switched Access Service.

Access Charges are applied on a per access minute basis. Access minute charges are accumulated over a monthly period.

3.5.1 Minimum Periods

Switched Access Service is provided for a minimum period of one month.

SECTION 3 - SWITCHED ACCESS SERVICE (Cont'd)

3.5 RATE REGULATIONS, (Cont'd)

3.5.2 Cancellation of Access Service Order

A Customer may cancel an Access Order for the installation of service on any date prior to notification by the Company that service is available for the Customer's Use or prior to the service date, whichever is later. The cancellation date is the date the Company receives written or verbal notice from the Customer that the order is to be canceled. The verbal notice must be followed by written confirmation within 10 days. If a Customer or End User is unable to accept Access Service within 30 calendar days of the original service date, the Access Order will be canceled and applicable charges will apply.

A. Prior to Firm Order Confirmation Date

If an Access Order is canceled prior to the Firm Order Confirmation date, no charges will apply.

B. On or After Firm Order Confirmation Date

If an Access Order is canceled on or after the Firm Order Confirmation date, the Customer will be billed a flat cancellation fee.

Cancellation Fee	\$50.00
------------------	---------

3.6 MONTHLY RECURRING AND NON-RECURRING CHARGES

3.6.1 Multiplexing

The Company may charge for multiplexing services. Multiplexing provides an arrangement for converting a single, higher capacity or bandwidth circuit to several lower capacity or bandwidth circuits. The following multiplexing arrangements are offered for use with Switched Access Service:

1. DS3 to DS1 Multiplexing charges specified in rate attachment apply when a DS3 Entrance Facility or DS3 Direct Trunked Transport is connected with DS1 Direct Trunked Transport.

SECTION 3 - SWITCHED ACCESS SERVICE (Cont'd)

3.6 MONTHLY RECURRING AND NON-RECURRING CHARGES (Cont'd)

3.6.1 Multiplexing (Cont'd)

2. DS1 to Voice Grade Multiplexing charges specified in rate attachment apply when a DS1 Entrance Facility or DS1 Direct Trunked Transport is connected with Voice Grade Direct Trunked Transport.

(T)

3.6.2 Access Order Charge

The Access Order Charge is applied to all customer requests for new Direct and Switched Access. In addition, the Access Order Charge is applicable to customer requests for additions and changes or rearrangements to existing Direct and Switched Access. The Access Order Charge will be applied on a per order, affirmative or otherwise, basis to each order received by the Company or copy of an order received by the Company.

3.6.3 Installation Charge

For certain facilities and equipment, a nonrecurring installation charge, as set forth in the rate attachment following, will be applied at the service wire center for each facility /equipment installation.

Issued: May 1, 2017

Resolution No:

Issued by:

Richard E. Ottalagana, Executive Vice President
One PaeTec Plaza, 600 Willowbrook Office Park
Fairport, New York 14450

May 8, 2017

Advice Letter No. 177

SECTION 3 - SWITCHED ACCESS SERVICE (Cont'd)

3.7 RATES AND CHARGES

3.7.1 Recurring Charges

A. Local Switching

Per Access Minute:

[See current rate sheets attached]

B. Local Transport

Per Access Minute:

[See current rate sheets attached]

C. 800 Data Base Access Service

Per Query:

[See current rate sheets attached]

SECTION 4 - DIRECT (DEDICATED) SERVICE

4.1 General

The various types of Company service offerings are described below. Company services are billed at predetermined monthly rates. Recurring charges are billed in advance of the month in which service is performed. In addition, the optional features and any extraordinary installation costs other than recurring and non-recurring charges may apply as described herein. Customers requesting these services may subscribe to services on a month-to-month basis, or for term discount plans of 1 to 5 years. Customers subscribing to a term discount plan may receive a discount on charges for these arrangements. Agreements for services in excess of 5 years will be negotiated on an ICB.

4.2 Service Configurations

There are two types of service configurations over which Company's services are provided: point-to-point service and multipoint service.

4.2.1 Point-To-Point Service

Point-To-Point Service connects two Customer-designated premises, either on a directly connected basis, or through a hub where multiplexing functions are performed.

4.2.2 Multipoint Service

Multipoint Services connect three or more Customer designated premises through a Company hub. There is no limitation on the number of locations connected via multipoint service. However, when more than three points are provided in tandem, the quality of service may be degraded. Multipoint service may be provided where technically possible. If Company determines that the requested characteristics for a multipoint service are not compatible, the Customer will be advised and given the opportunity to change the order within 60 days.

SECTION 4 - DIRECT (DEDICATED) SERVICE (Cont'd)

4.3 Service Descriptions and Technical Specifications

The following service descriptions and technical specifications will apply to Company's services. When references to Bellcore Technical Publications on file with the F.C.C. are made for performance criteria, the criteria will be considered objectives for Company's performance. In no case should the reference to these Bellcore standards be construed as creating any warranties on the part of Company. Technical publications are available for review by the Customer upon request.

4.3.1 Voice Grade Service (DS-0)

A Voice Grade Facility is a channel which provides voice frequency transmission capability in the normal frequency range of 300 to 3000 HZ and may be terminated as analog two-wire or four-wire, or where facilities permit, as a four-wire in a digital format when used in conjunction with another Voice Grade Facility termination at the other end. Voice Grade Facilities are provided between Customer designated locations or between a Customer designated location and a Company's hub.

Transmission specifications are defined in Bellcore Technical Reference TR-TSY-000335, issue 2 and PUB 41004, Table 4, and those publications referenced therein for Voice Grade frequency (300-3000hertz Voice Grade Transmission).

Issued: May 1, 2017

Resolution No:

Issued by:

Richard E. Ottalagana, Executive Vice President
One PaeTec Plaza, 600 Willowbrook Office Park
Fairport, New York 14450

May 8, 2017

Advice Letter No. 177

SECTION 4 - DIRECT (DEDICATED) SERVICE (Cont'd)

4.3 Service Descriptions and Technical Specifications (Cont'd)

4.3.2 Digital Data Service (DDS)

A Digital Data Channel is a channel for duplex four-wire transmission of synchronous serial data at rates of 2.4, 4.8, 9.6, 19.2, 56, or 64 Kbps. The actual bit rate is a function of the channel interface selected by the Customer. The channel provides synchronous service with timing provided by Company, through Company facilities to the Customer in the received bit stream. Digital Data channels are provided only between Customer designated locations and/or between Customer designated locations and a Company's hub.

4.3.3 DS-1 Service

DS-1 Service, or Digital Signal Level 1 Service, is a channel for the transmission of 1.5644 Mbps data. The actual bit rate and framing format is a function of the channel interface selected by the Customer. DS-1 Channels are provided between Customer designated locations and between Customer designated locations and a Company's hub.

Technical standards are defined in Bellcore Technical Reference TR-NPL-000054, TR-TSY-000342, TR-TSY-000194, and PUB 62508, PUB 62411, PUB 62411A.

4.3.4 Type I Channels

Type I digital channels are provided where both endpoints of a channel are served by the Company's network. Rates for Type I Channels are provided in Section 7 of this tariff.

SECTION 4 - DIRECT (DEDICATED) SERVICE (Cont'd)

4.3 Service Descriptions and Technical Specifications (Cont'd)

4.3.5 Type II Channels

Type II digital channels are provided where at least one endpoint of a channel is served by the network of an entity with whom the company's network is interconnected; such channels are provided via a combination of the Company's facilities and the facilities of the interconnected entity. Rates for the portions of the service provided over the company's facilities are based on the rates for the corresponding Type I Channel rates. Rates for the portion of the service provided over the facilities of the interconnected entity are based on the rates charged the Company by the interconnected entity. The Company may apply a service charge or mark-up to the rates charged the Company by the interconnected entity.

4.3.6 DS-3 Service

DS-3 Service, or Digital Signal Level 3 Service, is a channel for the transmission of 44.736 Mbps data. The actual bit rate and framing format is a function of the channel interface selected by the Customer. DS-3 Channels are provided between Customer designated locations and/or between Customer designated locations and a Company's hub. DS-3 service is provided with an electrical interface. As an option, this service may be provided to a Customer with an optical interface at the Customer's premises. Services with this option will terminate in Company's Optical Line Terminating Equipment (OLTE) located in Company's hub. The OLTE located at the Customer's premises is subject to the mutual agreement of the parties, and must be compatible with the OLTE located in Company's hub. The optical interface option is available only where facilities permit, and is offered on an Individual Case Basis (ICB)

Technical standards are defined in Bellcore Technical Reference TR-NPL-000054, TR-TSY-000342, TR-TSY-000194, and PUB 62508, PUB 62411, PUB 62411A.

Issued: May 1, 2017

Resolution No:

Issued by:

Richard E. Ottalagana, Executive Vice President
One PaeTec Plaza, 600 Willowbrook Office Park
Fairport, New York 14450

May 8, 2017

Advice Letter No. 177

SECTION 4 - DIRECT (DEDICATED) SERVICE (Cont'd)

4.3 Service Descriptions and Technical Specifications (Cont'd)

4.3.7 DS-3 Packaging

DS-3 services may be ordered in multiples as specified in the Dedicated Services Rates and Charges Section. These services are offered in the same configuration as DS-3 service (i.e. either electrical or optical interface), and with the same technical specifications.

4.3.8 Fractional DS-1 Service

Fractional DS-1 service consists of 2 to 24 DS-0 or DDS channels between two Customer designated locations, utilizing DS-1 level facilities, and multiplexing arrangements.

SECTION 4 - DIRECT (DEDICATED) SERVICE (Cont'd)

4.3 Service Descriptions and Technical Specifications (Cont'd)

4.3.9 Multiplexing Services

Multiplexing is provided in the following configurations:

M13 Multiplexing (ICB)

An arrangement that converts a 44.736 Mbps channel into 28 DS-1 channels using digital time division multiplexing.

DS-1 to DS-0 Multiplexing

An arrangement that converts a 1.544 Mbps channel into 24 channels for use with Voice Grade Facilities or DDS.

4.3.10 Customer Provided Equipment

Customer provided terminating equipment such as CSUs, multiplexers, and other terminating equipment may, at the Customer's request, be provided by the Customer, at the Customer's expense. Company makes no guarantees or warranties as to the performance of Customer provided equipment.

4.3.11 Entrance Facility

The Entrance Facility provides the transmission path and the interface between the Company's serving wire center and customer provided facilities at the point of termination at the customer designated location.

Switched Access is provided in a number of separate Entrance Facilities. Each Entrance Facility provides a specified facility interface (e.g., two-wire, four-wire, DS1, etc.) Provision of the Entrance Facility and any Optional Arrangements

SECTION 4 - DIRECT (DEDICATED) SERVICE (Cont'd)

4.3 Service Descriptions and Technical Specifications (Cont'd)

Entrance Facility (Cont'd)

The following Standard Entrance Facilities are available:

DS1 Digital

DS3 Digital

Optical Fiber OC3, OC12, OC48

The number of Entrance Facilities provided is determined by the customer's order for service.

In cases where the ordering customer provides its own access facilities through a vendor or other competitive access provider, the access order installation charge and an access order charge will be waived. A monthly recurring port charge applies to Customer entrance facilities regardless of type or method of provisioning. The port charge rates may be found in the rate section and are per facility ordered.

Issued: May 1, 2017

Resolution No:

Issued by:

Richard E. Ottalagana, Executive Vice President
One PaeTec Plaza, 600 Willowbrook Office Park
Fairport, New York 14450

May 8, 2017

Advice Letter No. 177

SECTION 4 - DIRECT (DEDICATED) SERVICE (Cont'd)

4.4 Rate Categories

There are seven rate categories that may apply to Company's Services.

4.4.1 Channel Terminations (CT) / Local Distribution Channel (LDC)

The Channel Termination Rate Category provides for the communications path between a Customer designated premises, and another Customer designated premises. Included as part of the Channel Termination is a standard channel interface arrangement which defines the technical characteristics associated with the type of facilities to which the Company's service is to be connected, and the type of signaling capability (if any). One channel Termination charge applies per Customer designated premises at which the service is terminated.

4.4.2 Channel Mileage Termination (CMT) - Fixed

This rate element applies per termination whenever there is mileage associated with the channel; a channel has mileage associated with it when the endpoints are located in geographic areas normally served out of separate Telephone Company end offices. Different charges may apply depending on whether the connection is a Type I (on-Net) or Type II (off-net) connection.

4.4.3 Channel Mileage (CM) - Per Mile

This rate element applies whenever there is mileage associated with the channel. The unit rate is multiplied by the number of miles (Interoffice Mileage) between the two Telephone end offices which normally serve the geographic areas in which the endpoints of the channel are located. Interoffice Mileage is determined according to the V&H coordinates method set forth in Section 2.10.2. Fractions of a mile are rounded up to the next whole mile before rates are applied. Different charges may apply depending on whether the connection is a Type I (on-Net) or Type II (off-net) connection.

Issued: May 1, 2017

Resolution No:

Issued by:

Richard E. Ottalagana, Executive Vice President
One PaeTec Plaza, 600 Willowbrook Office Park
Fairport, New York 14450

May 8, 2017

Advice Letter No. 177

SECTION 4 - DIRECT (DEDICATED) SERVICE (Cont'd)

4.4 Rate Categories (Cont'd)

4.4.4 Optional Features and Functions

The Optional Features and Functions Rate Category provides for optional services which may be added to a Company's service to improve its quality or characteristics to meet specific communications requirements. These services are not necessarily identifiable with specific equipment, but rather represent the end result in terms of performance characteristics which may be obtained. These characteristics may be derived using various combinations of equipment.

4.4.5 Extraordinary Charges

From time to time, customers may request special services not addressed specifically by rate elements in this tariff, or services to locations that may cause Company to incur extraordinary expenses not contemplated in the provision of standard service offerings. These costs include, but are not limited to:

- Additional construction costs
- Building space rental or rights-of-way costs
- Additional equipment
- Special facilities routing

In these cases, the Customer will be billed additional charges computed on an ICB. Special services not addressed in this tariff shall be approved by the Commission prior to the provision of such service.

SECTION 4 - DIRECT (DEDICATED) SERVICE (Cont'd)

4.4 Rate Categories (Cont'd)

4.4.6 Volume Discounts

Discounts for specified dollar volumes of traffic to a specific location or aggregate dollar volumes may apply, as specified in this tariff, to customers that subscribe to substantial volumes of Company's services.

4.4.7 Term Discounts

Customers will be eligible for discounts for executing agreements for services for 1 to 5 years, as specified in this tariff.

4.5 Application of Rate Elements

The rate elements described in F1 of this tariff will be applied as follows:

4.5.1 Point-To-Point Services

- Channel Terminations (when applicable)
- Channel Mileage (when applicable)
- Optional Features and Functions (when applicable)
- Extraordinary Charges (when applicable)
- Volume Discounts (when applicable)
- Term Discounts (when applicable)

4.5.2 Multipoint Services

- Channel Terminations (one per designated Customer location)
- Channel Mileage (when applicable)
- Optional Features and Functions (when applicable)
- Extraordinary Charges (when applicable)
- Volume Discounts (when applicable)
- Term Discounts (when applicable)

SECTION 4 - DIRECT (DEDICATED) SERVICE (Cont'd)

4.6 Regulations and Computations of Mileage

- 4.6.1 Calls originating in one time period and terminating in another will be billed in proportion to the rates in effect during different segments of the call.
- 4.6.2 All times refer to local time.
- 4.6.3 All inter-city services are rated according to the mileage between the Company's Point of Presence in each city.
- 4.6.4 Airline mileage, used in connection with determining rates for intercity portions of services and facilities, is obtained by using the "V" and "H" coordinates assigned to each point as set forth in (e) below. This procedure is referenced in the AT&T Tariff FCC No. 10. To determine the airlines distance between any two locations, proceed as follows:
 - A) Utilize the "V" and "H" coordinates for each Customer designated location.
 - B) Obtain the difference between the "V" coordinates of each of the locations. Obtain the difference between the "H" coordinates.
 - C) Square each difference obtained in step (ii) above.
 - D) Add the square of the "V" difference and the "H" difference obtained in step (iii) above.

Issued: May 1, 2017

Resolution No:

Issued by:

Richard E. Ottalagana, Executive Vice President
One PaeTec Plaza, 600 Willowbrook Office Park
Fairport, New York 14450

May 8, 2017

Advice Letter No. 177

SECTION 4 - DIRECT (DEDICATED) SERVICE (Cont'd)

4.6 Regulations and Computations of Mileage (Cont'd)

4.6.4 (Cont'd)

- E) Divide the sum of the square by 10. Round to the next higher whole number if any fraction is obtained.
- F) Obtain the square root of the whole number result obtained above. Round to the next higher whole number if any fraction is obtained. This is the airline mileage.
- G) Formula =
$$\frac{(V1 - V2)^2 + (H1 - H2)^2}{10}$$

SECTION 4 - DIRECT (DEDICATED) SERVICE (Cont'd)

4.7 Contract Rates - Special Pricing Arrangements-ICB

4.7.1 In lieu of the rates otherwise set forth in this tariff, rates and charges, including minimum usage, installation, special construction and recurring charges for Company's services may be established at negotiated rates on an ICB, taking into account the nature of the facilities and services, the costs of construction and operation, the volume of traffic, the length of service commitment by the Customer, and use of facilities by other customers. Such arrangements shall be considered Special Pricing Arrangements, the terms of which will be set forth in individual Customer contracts. However, unless otherwise specified, the terms, conditions, obligation and regulation set forth in this tariff shall be incorporated into, and become a part of, said contract, and shall be binding on Company and Customer. Specialized rates or charges will be made available to similarly situated customers on a non-discriminatory basis.

4.7.2 In addition to any rate or charge established by the Company, the Customer will also be responsible for any recurring or non-recurring charges imposed by local exchange telephone companies incurred by or on behalf of the Customer in establishing and maintaining service. Such charges may be billed by the Company or directly by the local exchange company, at the Company's option.

4.8 Back Billing

Company shall be entitled to revise bills previously rendered to adjust for previously rendered unbilled service, or adjust upward a bill previously rendered, assuming that the customer was aware of the unbilled services during the period the services were unbilled, for a period of six years after the service was rendered.

Issued: May 1, 2017

Resolution No:

Issued by:

Richard E. Ottalagana, Executive Vice President
One PaeTec Plaza, 600 Willowbrook Office Park
Fairport, New York 14450

May 8, 2017

Advice Letter No. 177

SECTION 4 - DIRECT (DEDICATED) SERVICE (Cont'd)

4.9 Taxes

4.9.1 Sales, Use and Excise Taxes

In addition to all recurring, non-recurring, usage or special charges, Customer shall also be responsible for and shall pay all applicable federal, state and local sales, use and excise taxes.

4.10 **[Reserved]**

4.11 Temporary Promotional Programs

The Company may establish temporary promotional programs, wherein it may waive or reduce recurring or non-recurring charges, to introduce a present or potential Customer to a service not previously received by the Customer. The terms of promotional programs will be filled with the Commission subject to the requirements of applicable law, except if the promotion is to reduce rates.

SECTION 5 - END USER ACCESS SERVICE (CARRIER COMMON LINE)

5.1 GENERAL

The Company will provide End User Access Service to Customers in conjunction with Switched Access Service provided in Section 3 of this tariff. End User Access provides for the use of End Users' Company-provided common lines by Customers for access to such End Users to furnish Intrastate Communications.

5.2 LIMITATIONS

No telephone number or detailed billing will be provided with End User Access. Directory listings and intercept arrangements are not included in the rates and charges for End User Line Access.

5.3 APPLICATION OF INTRASTATE CHARGES

Intrastate rates apply only to that portion of End User Access Service provided for intrastate usage. Jurisdictional reporting is required as described in Section 2.10.7 of this tariff.

5.4 RATES AND CHARGES

Per access minute:

	Minimum	Maximum
Terminating	\$0.00	\$0.05
Originating	\$0.00	\$0.05

Issued: May 1, 2017

Resolution No:

Issued by:

Richard E. Ottalagana, Executive Vice President
One PaeTec Plaza, 600 Willowbrook Office Park
Fairport, New York 14450

May 8, 2017

Advice Letter No. 177

SECTION 6 - SPECIAL ARRANGEMENTS

6.1 SPECIAL CONSTRUCTION

6.1.1 Basis for Charges

Basis for Charges where the Company furnishes a facility or service for which a rate or charge is not specified in the Company's tariffs, charges will be based on the costs incurred by the Company (including return) and may include:

- A. nonrecurring charges;
- B. recurring charges;
- C. termination liabilities; or
- D. combinations of (a), (b), and (c).

SECTION 6 - SPECIAL ARRANGEMENTS (Cont'd)

6.1 SPECIAL CONSTRUCTION (Cont'd)

6.1.2 Termination Liability

To the extent that there is no other requirement for use by the Company, a termination liability may apply for facilities specially constructed at the request of a customer.

- A. The period on which the termination liability is based is the estimated service life of the facilities provided.
- B. The amount of the maximum termination liability is equal to the estimated amounts (including return) for:
 - 1. Costs to install the facilities to be provided including estimated costs for the rearrangements of existing facilities. These costs include:
 - a. equipment and materials provided or used;
 - b. engineering, labor, and supervision;
 - c. transportation; and
 - d. rights of way and/or any required easements;
 - 2. license preparation, processing, and related fees;
 - 3. tariff preparation, processing and related fees;
 - 4. cost of removal and restoration, where appropriate; and
 - 5. any other identifiable costs related to the specially constructed or rearranged facilities.

Issued: May 1, 2017

Resolution No:

Issued by:

Richard E. Ottalagana, Executive Vice President
One PaeTec Plaza, 600 Willowbrook Office Park
Fairport, New York 14450

May 8, 2017

Advice Letter No. 177

SECTION 6 - SPECIAL ARRANGEMENTS (Cont'd)

6.2 NON-ROUTINE INSTALLATION AND/OR MAINTENANCE

At the customer's request, installation and/or maintenance may be performed outside the Company's regular business hours, or (in the Company's sole discretion and subject to any conditions it may impose) in hazardous locations. In such cases, charges based on the cost of labor, material, and other costs incurred by or charged to the Company will apply. If installation is started during regular business hours but, at the Customer's request, extends beyond regular business hours into time periods including, but not limited to, weekends, holidays, and/or night hours, additional charges may apply.

6.3 INDIVIDUAL CASE BASIS (ICB) ARRANGEMENTS

Rates for ICB arrangements will be developed on a case-by-case basis in response to a bona fide request from a customer or prospective customer for services which vary from tariffed arrangements. Rates quoted in response to such requests may be different for tariffed services than those specified for such services in the Rate Attachment. ICB rates will be offered to customers in writing and will be made available to similarly situated customers. A summary of each ICB contract pricing arrangement offered pursuant to this paragraph will be filed as an addendum to this Tariff within 30 days after the contract is signed by both the Company and the customer. The following information will be included in the summary:

- 1) LATA and type of switch
- 2) Service description
- 3) Rates and charges
- 4) Quantity
- 5) Length of the agreement.

Issued: May 1, 2017

Resolution No:

Issued by:

Richard E. Ottalagana, Executive Vice President
One PaeTec Plaza, 600 Willowbrook Office Park
Fairport, New York 14450

May 8, 2017

Advice Letter No. 177

SECTION 6 - SPECIAL ARRANGEMENTS (Cont'd)

6.4 EQUIPMENT INSTALLED OR WORK PERFORMED IN COMPANY SWITCH SITE OR OTHER OPERATIONAL LOCATIONS

6.4.1 General Administration

In order that the Company may interconnect its network with Customers, Customers may be required to install equipment or network services on Company premises including but not limited to switching centers. This section outlines terms and conditions for any Customer, vendor or other person performing installation, interconnection, maintenance and repair and any other telecommunications or information services in those spaces. The Company will require that the Customer or vendor provide information necessary to support installation of equipment or facilities during the period prior to the work being performed. This information will be specified in a separate document and will be reviewed by the Company engineering teams. Specifically, further details are as specified by Company engineers in review and approval of installation and power related Methods of Procedure (MOP).

Company operations personnel have been instructed NOT to allow any vendor to perform any work within the PAETEC space until specifications and MOP paperwork has been received.

6.4.2 Technical Guidelines for Working with Power in Company Operations Sites

It is the Company's goal to maintain a safe, clean and hazardous free work environment in Company operational space. These technical specifications and work processes must be followed in order to avoid circuit interruption, retail outages and power failures;

- a. All equipment installed in PAETEC operational sites is required to be DC powered.
- b. Fuse assignments are located on the breaker distribution fuse box (BDFB). The MOP will specify panel position as well as correct fuse amperage.
- c. Cable size will also be specified and will be tapped down to #6AWG for termination using compression lugs.

Issued: May 1, 2017

Resolution No:

Issued by:

Richard E. Ottalagana, Executive Vice President
One PaeTec Plaza, 600 Willowbrook Office Park
Fairport, New York 14450

May 8, 2017

Advice Letter No. 177

SECTION 6 - SPECIAL ARRANGEMENTS (Cont'd)

6.4 EQUIPMENT INSTALLED OR WORK PERFORMED IN COMPANY SWITCH SITE
OR OTHER OPERATIONAL LOCATIONS (Cont'd)

6.4.2 Technical Guidelines for Working with Power in Company Operations Sites
(Cont'd)

- d. Inventory of materials on-site and continuous verification of all equipment, tools and hardware is important. Company personnel must be contacted immediately if a deficiency is noted.
- e. Safety glasses will be worn, all jewelry will be removed and any other personal safety guidelines deemed appropriate must be followed during this procedure.
- f. "Hot" buss bars will be protected with rubber mats. These materials are to be secured so they will stay in place during work activity.
- g. Crimps must be made with appropriate crimping tools.
- h. Heat shrink insulation must be applied to cover all cable butts.
- i. If there are existing cables within the space procedures should be modified to follow existing cable patterns to assure uniformity of work.
- j. All open ends of cable and lugs/connectors installed on cables are to be taped or capped at all times until they are being terminated.
- k. All equipment relay racks and added equipment must be grounded to existing ground halo before any power cable terminations are made.
- l. Verify absence of alarms on any involved system or component equipment before beginning procedures.

IMPORTANT: Before beginning any installation of equipment or power provisioning, a direct current (DC) amp reading must be taken on the 750MCM ground. The reading must be taken again after the installation is complete including powering up equipment. Both readings must be witnessed and verified by Company personnel. If there is a change in the reading, the reason for the change must be determined and corrected before the Company will accept the work.

Issued: May 1, 2017

Resolution No:

Issued by:

Richard E. Ottalagana, Executive Vice President
One PaeTec Plaza, 600 Willowbrook Office Park
Fairport, New York 14450

May 8, 2017

Advice Letter No. 177

SECTION 6 - SPECIAL ARRANGEMENTS (Cont'd)

6.4 EQUIPMENT INSTALLED OR WORK PERFORMED IN COMPANY SWITCH SITE
OR OTHER OPERATIONAL LOCATIONS (Cont'd)

6.4.2 Technical Guidelines for Working with Power in Company Operations Sites
(Cont'd)

Upon review of applicable MOP, BDFB, circuit breaker assignments and power cable sizes will be provided by the Company engineering representative for power, heating, ventilation and air conditioning.

The vendor or Customer, with the assistance of a Company representative, will determine cable routes between BDFB and the relay rack power connection for termination to the equipment to be powered. The cable length should be measured to allow extra footage for working cables and forming turns.

Cables must be cut to length, taping ends and placing cable tags for identification on both ends. Cables will be at a predetermined size (AWG) on the cable relay rack and H-tapped to 6 AWG for routing into and connecting to equipment at both ends. Black and red #6 AWG must be used.

Open rear of BDFB and prepare work area according to guidelines in general procedures above.

Customer or vendor personnel are authorized to disable power on circuits to be connected at the BDFB.

Verification of the absence of power at output post of circuit breakers in question is required.

Place cables on cable relay racks of the determined route and secure with temporary ties.

H-tap 6 AWG feeders to XX AWG cable runs at the BDFB end, staggering the taps so that they will not be adjacent to each other.

Issued: May 1, 2017

Resolution No:

Issued by:

Richard E. Ottalagana, Executive Vice President
One PaeTec Plaza, 600 Willowbrook Office Park
Fairport, New York 14450

May 8, 2017

Advice Letter No. 177

SECTION 6 - SPECIAL ARRANGEMENTS (Cont'd)

6.4 EQUIPMENT INSTALLED OR WORK PERFORMED IN COMPANY SWITCH SITE
OR OTHER OPERATIONAL LOCATIONS (Cont'd)

6.4.2 Technical Guidelines for Working with Power in Company Operations Sites
(Cont'd)

Secure feeders in BDFB to approximate location of termination.

Prepare cable ends and terminate to appropriate assignments at rear of BDFB. Land RETURN cable first. This applies for A and B feed cables for each piece of equipment

Lace cables to cable rack from BDFB to area where the equipment to be powered is located.

At this point, there should be no power on -48VDC leads and there should be ground on the RETURN cables.

H-tap 6 AWG feeders to XX AWG cable runs at the equipment end, staggering the taps so that they will not be adjacent to each other.

Prepare 6AWG cable ends and land as required at equipment to be powered in the associated relay rack location.

Customer or vendor must activate the A feed circuit breaker (BDFB) for each piece of equipment and verify the presence of -48VDC on the A feed at the equipment.

Repeat the above steps for the B feeds.

At equipment end in the associated relay rack space, replace any removed covers and verify cable tags and labels as required.

At BDFB end, remove any insulating materials, verify cable tags and label circuit breakers as required. Close back of BDFB.

At all times, please clean up work area and dispose of any waste material in appropriate containers.

SECTION 6 - SPECIAL ARRANGEMENTS (Cont'd)

6.4 EQUIPMENT INSTALLED OR WORK PERFORMED IN COMPANY SWITCH SITE
OR OTHER OPERATIONAL LOCATIONS (Cont'd)

6.4.3 Requirements for Entrance Facility Builds and Equipment Installation

Complete diversity is required both into and out of each site for all fiber optic cables. This is further defined to mean that completely diverse routes, that do not cross one another, are to be taken from each diverse entrance into the building to the fiber distribution panel (FDP). At no time shall these fiber optic cables be in the same conduit or pull box or cross one another. Should the fiber optic cables be in the same chase within the building, they shall be placed in different conduits that are separated by the maximum amount of space available.

All fiber optic cables shall be fusion spliced in a Customer or vendor provided fusion splice closure (SC) that is fire-retardant, as required by standard industry specifications. All fiber terminations shall be such that a Company jumper ('pig-tail'), with an industry standard SC connector, extends from the fiber splice closure to terminate in the back of the FDP, via approved fiber optic cable troughs or protection sleeves.

Both fiber optic and coaxial hand-offs to the Company shall terminate on Customer or vendor provided FDP and DSX-3 panels. Customer or vendor engineering representatives shall specify the type and model number for these FDP and DSX-3 panels in each site. In addition, the Company and the Customer or vendor will work together to determine where the FDP and DSX-3 panels are to be installed (see appropriate section for equipment and rack assignments). Any and all fiber optic jumpers (pig-tails) and coaxial cabling required to extend these hand-offs shall also be purchased, provided, and placed by the Customer or vendor or its authorized representative. All fiber optic jumpers (pig-tails) and FDPs purchased, provided, and placed shall utilize the industry standard SC fiber connectors.

The Customer or vendor is responsible for purchasing, providing, and placing any and all DC power materials and cabling required (fuse panel, fuses, etc). This includes all items required from the Company assigned BDFB location to the Customer or vendor's equipment for both the required "A" and "B" DC power feeds. The Customer or vendor engineering representative, in conjunction with Company operations personnel, shall determine who makes the connection to the existing BDFB. Regardless of whether the Customer or vendor or the Company makes these connections, this work activity shall include all labor required in completing the task.

Issued: May 1, 2017

Resolution No:

Issued by:

Richard E. Ottalagana, Executive Vice President
One PaeTec Plaza, 600 Willowbrook Office Park
Fairport, New York 14450

May 8, 2017

Advice Letter No. 177

SECTION 6 - SPECIAL ARRANGEMENTS (Cont'd)

6.4 EQUIPMENT INSTALLED OR WORK PERFORMED IN COMPANY SWITCH SITE
OR OTHER OPERATIONAL LOCATIONS (Cont'd)

6.4.3 Requirements for Entrance Facility Builds and Equipment Installation (Cont'd)

The Customer or vendor is also responsible for providing the relay rack in which the system will be installed. All equipment to be placed within one of the Company sites is required to be DC powered.

In addition, the detailed power specifications of the system to be installed shall also be provided to the Company engineering representative during the initial site survey contact. This includes, but is not limited to power requirements, heat dissipation, etc. Other relevant sections of this tariff may apply.

6.4.4 MOP Requirements

All entrance facilities and equipment installations shall be preceded by the submission and acceptance of a separately published MOP.

6.4.5 Company Operational Times of Access

The Company will schedule the work with the Customer or vendor at the appropriate site. Any and all work activities completed by the Customer or vendor shall be done during the Company maintenance window. That window is 12:00 AM through 6:00 AM local time, Monday through Friday and not including holidays. The specific time that the physical work shall be done is to be determined solely by Company operations personnel responsible for each site and will be coordinated via the Company service coordinator (SPOC). Once complete, the Customer or vendor will provide "as-built" drawings to the Company SPOC. The Company will maintain these as-built drawings for each site. Any deviation from these times must be separately scheduled with the Company SPOC.

Issued: May 1, 2017

Resolution No:

Issued by:

Richard E. Ottalagana, Executive Vice President
One PaeTec Plaza, 600 Willowbrook Office Park
Fairport, New York 14450

May 8, 2017

Advice Letter No. 177

SECTION 6 - SPECIAL ARRANGEMENTS (Cont'd)

6.4 EQUIPMENT INSTALLED OR WORK PERFORMED IN COMPANY SWITCH SITE
OR OTHER OPERATIONAL LOCATIONS (Cont'd)

6.4.6 Company Access to Customer or Vendor Space

The Customer or vendor will provide the Company with unrestricted access to the Space on 24 hours advance notice. In the event of an emergency, the Company will have immediate unrestricted access to the space. The Customer or vendor will provide a contact name and phone number that will serve as a 24-hour maintenance and emergency contact telephone number for trouble notification. The Customer or vendor will also post this number on its equipment located in the space.

6.4.7 Insurance

Any person or entity, prior to being allowed entrance into the Company operational sites, whether a Customer or vendor or under the hire of a Customer or vendor, must present a certificate of insurance. The Customer or vendor agrees to maintain insurance for its equipment located in the space in the amounts and types listed below, and to name the Company as an additional insured under these policies:

- A. Worker's Compensation/Employer's Insurance in accordance with all applicable federal and state statutory requirements.
- B. Commercial General Liability – single limit for bodily injury and property damage of \$1,000,000 for each occurrence and General and Products Liability aggregates of not less than \$2,000,000.
- C. Excess or Umbrella Liability coverage – combined single limit for bodily injury and property damage of not less than \$1,000,000 for each occurrence with an annual aggregate of \$1,000,000 to apply in excess of all other insurance coverages required above.

Issued: May 1, 2017

Resolution No:

Issued by:

Richard E. Ottalagana, Executive Vice President
One PaeTec Plaza, 600 Willowbrook Office Park
Fairport, New York 14450

May 8, 2017

Advice Letter No. 177

SECTION 6 - SPECIAL ARRANGEMENTS (Cont'd)

6.4 EQUIPMENT INSTALLED OR WORK PERFORMED IN COMPANY SWITCH SITE
OR OTHER OPERATIONAL LOCATIONS (Cont'd)

6.4.7 Insurance (Cont'd)

The named insured certificate holder must be shown to include:

PAETEC
Attention: General Counsel
600 Willowbrook Office Park
Fairport, NY 14450

The Customer or vendor will provide the Company with certificates of insurance upon request. Customer or vendor will provide the Company with certified copies of these insurance policies within five (5) days after receiving a request from the Company. The Customer or vendor will obtain additional insurance coverage if the landlord of the premises where the space is located requires it.

The Customer or vendor will require any contractor it uses at the premises to comply with these insurance requirements and, upon request, to supply the Company with proof of this coverage before beginning work.

The Company will not insure or be responsible for any loss or damage to any property owned or leased by the Customer or vendor or its employees or agents.

6.4.8 Industry Standard Technical Compliance

Any person or entity other than the Company certifies that equipment installed in a Company operational site is in compliance with Criteria Level 1 requirement as outlined in the Telcordia Special Report SR-3580, Issue 1.

Issued: May 1, 2017

Resolution No:

Issued by:

Richard E. Ottalagana, Executive Vice President
One PaeTec Plaza, 600 Willowbrook Office Park
Fairport, New York 14450

May 8, 2017

Advice Letter No. 177

SECTION 6 - SPECIAL ARRANGEMENTS (Cont'd)

6.4 EQUIPMENT INSTALLED OR WORK PERFORMED IN COMPANY SWITCH SITE
OR OTHER OPERATIONAL LOCATIONS (Cont'd)

6.4.9 Responsibilities of the Company

The Company will provide the Customer or vendor with certain access, wiring, equipment and services solely for the purpose of interconnecting the Customer's or vendor's equipment, which will be located on a Company operational premises, with PAETEC's network according to the terms and conditions contained in this tariff or in an individual case basis contract.

6.4.10 Use of Space

The Company grants the Customer or vendor a nonexclusive limited license to occupy the portion of the operational premises of relevance or, in other words, the space. The Customer or vendor agrees to use the Space only to install, maintain, and operate equipment to interconnect to the Company network. The Customer or vendor agrees that it is being granted only a license to occupy the space and not a real property interest in the space. The Customer's or vendor's occupancy of the space will serve as the Customer's or vendor's acceptance of the space. The Customer or vendor agrees to use the space only for the purposes described in the individual ICB or this tariff and not for any unlawful purpose. The Customer or vendor further agrees not to encumber the space in any manner. The Customer or vendor, and any approved subcontractors and/or representatives agree not to smoke in the space, to keep the space in a clean and safe condition and to comply with any rules of the applicable landlord and/or the Company.

The Customer or vendor use of the space throughout the term of an ICB or this tariff is contingent upon the Company continuing to own or lease the premises where the space is located.

If Customer or vendor does not remove its equipment from the space within thirty (30) days following the termination of an ICB contract or as specified in this tariff, the Company may, at the Customer's or vendor's expense, remove equipment from the space and ship it to Customer's or vendor's last known address.

Issued: May 1, 2017

Resolution No:

Issued by:

Richard E. Ottalagana, Executive Vice President
One PaeTec Plaza, 600 Willowbrook Office Park
Fairport, New York 14450

May 8, 2017

Advice Letter No. 177

SECTION 6 - SPECIAL ARRANGEMENTS (Cont'd)

6.4 EQUIPMENT INSTALLED OR WORK PERFORMED IN COMPANY SWITCH SITE OR
OTHER OPERATIONAL LOCATIONS (Cont'd)

6.4.10 Use of Space (Cont'd)

The Customer or vendor will not unreasonably interfere with the Company's or any other tenant's use of the premises. The Company will not unreasonably interfere with the Customer or vendor use of the space and will make reasonable efforts to prevent others from interfering with the Customer or vendor use of the space

6.4.11 License Fee, Taxes and Other Fees

The Customer or vendor may request additional space at the premises at any time during the term of an ICB contract or this tariff. The Company may, but is not obligated to, provide Company with additional space. In the event the Company does provide the Customer or vendor with additional space, the Customer or vendor agrees to pay an appropriate license fee if required by the Company. That fee will be subject to ICB negotiations and contract terms.

6.4.12 Notice of Termination of Services

If the Customer or vendor removes its equipment from the space or terminates the ICB contract or other governing contractual arrangement, the Customer or vendor will provide the Company ninety (90) day prior written notice.

6.4.13 Maintenance

The Customer or vendor is responsible for performing all maintenance and repair on its equipment. The Company has no obligation to maintain Customer's or vendor's equipment.

SECTION 6 - SPECIAL ARRANGEMENTS (Cont'd)

6.4 EQUIPMENT INSTALLED OR WORK PERFORMED IN COMPANY SWITCH SITE OR
OTHER OPERATIONAL LOCATIONS (Cont'd)

6.4.14 Landlord Services

The Customer or vendor agrees that the Company is not obligated to perform any services normally provided by a landlord at any leased premises. Services provided by a landlord may be made available to the Customer or vendor but only on the same basis as they are available to the Company. The Company has no liability for the delay or failure of any landlord to perform any service.

6.4.15 Improvements to Space

The Customer or vendor shall provide the Company all plans for improvements to the spaces. The Company shall have the right to review, and in its sole discretion the Company may provide written approval for all plans and contractors before the Customer or vendor makes any improvements to the space. The Customer or vendor, or its agent or contractor, must guarantee in writing that the workmanship of any improvement to the space will be free from defects for one year after completion. All improvements will be made at the Customer's or vendor's expense, will become part of the space, and may not be removed from the space at the end of the ICB contract or other agreement.

6.4.16 Interconnection with Third Parties

The Customer or vendor may connect to telecommunications services provided by third parties at the space only if the Company gives its prior written consent. The Company will provide the Customer or vendor with entrance facilities and cross connections throughout the term of the ICB or other agreement.

SECTION 6 - SPECIAL ARRANGEMENTS (Cont'd)

6.4 EQUIPMENT INSTALLED OR WORK PERFORMED IN COMPANY SWITCH SITE OR
OTHER OPERATIONAL LOCATIONS (Cont'd)

6.4.17 Relocation of Equipment

The Company may require the Customer or vendor to relocate its equipment on sixty (60) days prior written notice. In the event of an emergency beyond the Company's control, the Customer or vendor shall relocate its equipment immediately upon notification. If the Customer or vendor is required by the Company to relocate for any reason, the Company will assume half the costs associated with any such relocation. The Company will provide a good faith estimate to Customer of such costs. The Company will seek to provide the Customer or vendor with a comparable alternative location if the Customer or vendor is required to relocate its equipment.

6.4.18 Lien on Equipment

The Company will have no rights to or interest in the equipment other than statutory rights, if any, granted a landlord with respect to the property of a tenant (commercial or residential), and those set forth in this tariff or in an ICB contract. Except as provided herein, the equipment shall remain the sole property of the Customer or vendor. However, if the Customer or vendor fails to pay any amounts due to the Company or is in default of any agreement with the Company, the Company will have a lien on the equipment and all other personal property of Customer or vendor that may be located in or on the premises. The Customer or vendor specifically waives any and all exemptions allowed by law with respect to such lien, which lien may be enforced by the Company by the taking and selling of such equipment and/or property (to be made in a commercially reasonable manner upon thirty (30) days written notice to the Customer or vendor), or such lien may be enforced in any other lawful manner available to the Company.

Issued: May 1, 2017

Resolution No:

Issued by:

Richard E. Ottalagana, Executive Vice President
One PaeTec Plaza, 600 Willowbrook Office Park
Fairport, New York 14450

May 8, 2017

Advice Letter No. 177

SECTION 6 - SPECIAL ARRANGEMENTS (Cont'd)

6.4 EQUIPMENT INSTALLED OR WORK PERFORMED IN COMPANY SWITCH SITE OR
OTHER OPERATIONAL LOCATIONS (Cont'd)

6.4.19 Notices

All notices under this tariff or ICB contracts must be in writing and sent via an overnight courier that provides evidence of delivery to the following address:

PAETEC
Attention: General Counsel
600 Willowbrook Office Park
Fairport, NY 14450

6.4.20 Limitation of Liability

Where not in conflict with other sections of this tariff, the Company will take reasonable precautions to prevent damage to the Customer or vendor equipment, however, PAETEC's liability for any damage to Company's equipment is limited to the amount of actual damages or \$1,000 dollars, whichever is less.

The Company will not be responsible for any special, indirect, consequential or incidental damages, including but not limited to lost profits. The Customer or vendor agrees to indemnify, defend and hold the Company harmless from any and all liabilities, losses, damages, claims, actions, expenses and costs (including attorney's fees) incurred by or asserted against the Company that result from:

- A. The customer or vendor use of the space;
- B. Any third party that the Customer or vendor permits to use or visit the space; and
- C. Any violation of these tariff terms or ICB contracts by the Customer or vendor; and
- D. The Customer or vendor in violation of any law or regulation.

Issued: May 1, 2017

Resolution No:

Issued by:

Richard E. Ottalagana, Executive Vice President
One PaeTec Plaza, 600 Willowbrook Office Park
Fairport, New York 14450

May 8, 2017

Advice Letter No. 177

SECTION 6 - SPECIAL ARRANGEMENTS (Cont'd)

6.4 EQUIPMENT INSTALLED OR WORK PERFORMED IN COMPANY SWITCH SITE OR
OTHER OPERATIONAL LOCATIONS (Cont'd)

6.4.21 Eminent Domain

In the event of a taking of all or any portion of the premises where the space is located by eminent domain (or conveyance by the landlord to an entity threatening eminent domain), these tariff terms with regard to the specific Customer or vendor service or equipment will terminate as of the date of such exercise or conveyance. The Company is not responsible to the Customer or vendor for the value of any unused portion of any term specified outside of the bounds of this tariff including ICB contract arrangements. The Customer or vendor may, however, seek relief from the landlord or appropriate authority.

6.4.22 Damage to Premises

Where not in conflict with other provisions of this tariff, if the space is damaged by fire or other casualty, the Company will notify the Customer or vendor and immediately and will repair, or cause the landlord to repair, the space so that it is returned to substantially the same condition as prior to the damage. If the Company fails to complete the repairs within a reasonable time period, the Customer or vendor may, as its sole remedy, vacate the space per terms of this tariff. The Company will be responsible for any damage to its own equipment if fire or other casualty damages the space. The Customer or vendor agrees to reimburse the Company for any damage to the Space that is caused by the Customer or vendor or its representatives or its equipment.

6.4.23 Subordination

The Customer or vendor acknowledges and agrees that this document is subject and subordinate to the Company's mortgage or lease for the premises where the space is located.

6.4.24 Rate and Charges

Rates for use of Company space, equipment or labor will be published on an individual case basis.

SECTION 7 - RECIPROCAL COMPENSATION ARRANGEMENTS

7.1 GENERAL

Reciprocal Compensation Arrangements are available to Other Network Providers (ONP) who are also certified providers of local exchange service. Under a Reciprocal Compensation Arrangement, the Company compensates the ONP for Company traffic terminating on the ONP's network and the ONP compensates the Company for ONP traffic terminating on the Company's network.

The Company will negotiate compensation arrangements with ONPs. However, in the absence of negotiated arrangements between the Company and ONPs, the Company's Reciprocal Compensation Arrangements to ONPs will be no higher than those of the incumbent carrier for the region in which that incumbent is providing service.

The Reciprocal Compensation Rate is specified in the Current Rate section at the end of the tariff.

Recognizing the technical constraints of cellular carriers and other smaller carriers where it is not technically possible for the Company to Interconnect directly to each of another carrier's switching offices, the Company will pay charges when requested by the carrier for traffic that it terminates on such carrier's network as specified above until such time as that carrier interconnects, through its own facilities or a third carrier's facilities, directly to a Company switching office or negotiates alternative arrangements.

7.2 MEASUREMENT OF ACCESS MINUTES AND DETERMINATION OF BALANCE

All traffic subject to a Reciprocal Compensation Arrangement will be considered terminating for usage measurement purposes, i.e., Company traffic is terminating to the ONP and ONP traffic is terminating to the Company. Usage measurement will begin when the Company entry switch receives answer supervision from the Company's end user's switching office or from the ONP's point of termination, whichever occurs later. Usage measurement will end when the Company entry switch receives disconnect supervision from the Company's end user's office or from the ONP's point of termination, whichever occurs first.

Issued: May 1, 2017

Resolution No:

Issued by:

Richard E. Ottalagana, Executive Vice President
One PaeTec Plaza, 600 Willowbrook Office Park
Fairport, New York 14450

May 8, 2017

Advice Letter No. 177

SECTION 7 – RECIPROCAL COMPENSATION ARRANGEMENTS (Cont'd)

7.3 OTHER USES

Where an ONP connects its network to the Company's network, the exchange of traffic will not be limited to traffic subject to reciprocal compensation. Other types of traffic are covered under switched access tariffs or other arrangements.

7.4 EXAMPLES

The following example illustrates the traffic that can flow over a connection between the Company and an ONP.

Example 1.

Call From an ONP Customer
To a Company Customer
(ONP Collocated at the Tandem)

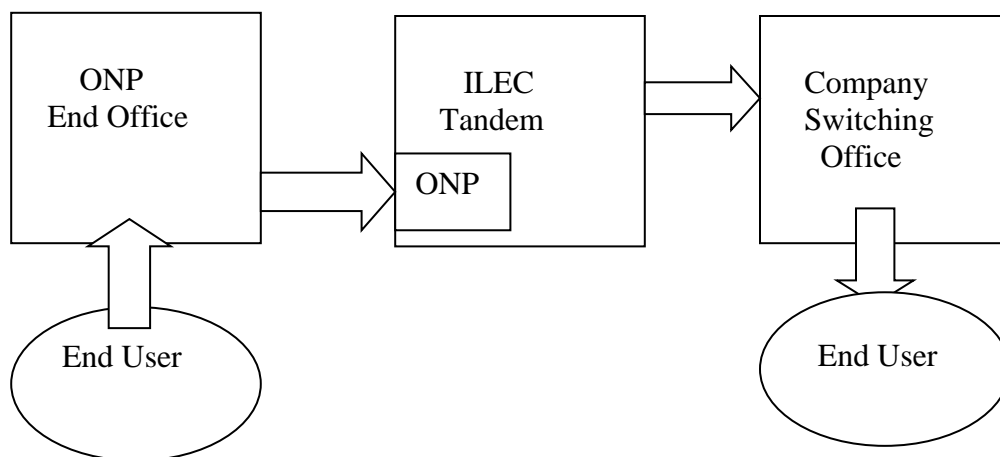

1. ONP pays Company ONP reciprocal compensation.

SECTION 7 – RECIPROCAL COMPENSATION ARRANGEMENTS (Cont'd)

7.4 EXAMPLES (Cont'd)

Example 2

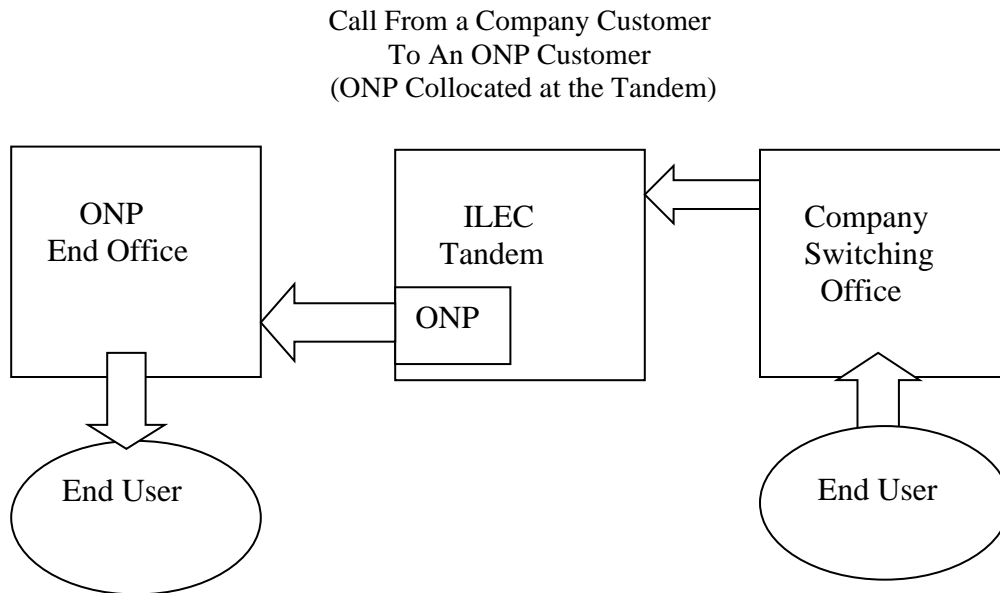

1. Company pays ONP reciprocal compensation where requested.

7.5 SWITCHED ACCESS

Switched access calls are governed by the provisions of this tariff and PaeTec's FCC #3

7.6 LOCAL NUMBER PORTABILITY

Calls from numbers ported by an ONP from other carriers and terminated by the Company will be billed to ONP as appropriate and in accordance with the sections above.

7.7 JURISDICTIONAL REPORTS

When a Customer or ONP orders Switched Access Service for both interstate and intrastate use, the Customer or ONP is responsible for providing reports as set forth in Section 2.11.7. Charges will be apportioned in accordance with those reports.

SECTION 8 - BILLING AND COLLECTION

8.1 GENERAL

The Company will provide the following services:

- Recording Service
- Automatic Number Identification (ANI)
- Billing Name and Address (BNA)
- Chargeable Optional Features
- 800 Database Access Service
- Blocking and Screening

All bills are presumed accurate, and shall be binding on the Customer unless notice of the disputed charge(s) is received by the Company within 90 days (commencing 5 days after such bills have been mailed or otherwise rendered per the Company's normal course of business). For the purposes of this section, "notice" is defined as written notice to the Company, containing sufficient documentation to investigate the dispute, including the account number under which the bill has been rendered, the date of the bill, and the specific items on the bill being disputed.

Issued: May 1, 2017

Resolution No:

Issued by:

Richard E. Ottalagana, Executive Vice President
One PaeTec Plaza, 600 Willowbrook Office Park
Fairport, New York 14450

May 8, 2017

Advice Letter No. 177

SECTION 8 - BILLING AND COLLECTION (Cont'd)

8.2 RECORDING SERVICE

Recording is the entering on magnetic tape or other acceptable media the details of customer messages originated through switched access service. Recording is provided 24 hours a day, 7 days a week.

The company will provide recording service in association with the offering of Feature Groups B for 900 Access Service, C, and D Switched Access Service for customer messages that can be recorded by company-provided automatic message accounting equipment. In addition, where the company records the customer messages on manual tickets, the company will provide recording service for the manual tickets and at offices where the company provides Feature Group A switched access service and has the ability to record the Feature Group A call detail with automatic message accounting equipment and mark the recorded call detail as Feature Group A call detail for a specific customer, the company will provide the recording service for Feature Group A switched access service. At the request of the customer, recording service will be provided for Feature Group D switched access service on an end office and type of call basis. Type of call means message telecommunications service (MTS) including 700 and 900 service, calls originating and/or terminating over a WATS access line, and station message detail recording for MTS and calls originating from a WATS access line.

The company will provide recording service in its operating territory. The minimum territory for which the company will provide recording service is all the appropriately equipped offices in a state operating territory for which the customer has ordered Feature Group A, B for 900 service, C, or D switched access service. A state operating territory of a particular telephone company includes all its LATAs or market areas which are located in the same state including the areas in contiguous states which are assigned to such LATAs or market areas and served by the same company.

Issued: May 1, 2017

Resolution No:

Issued by:

Richard E. Ottalagana, Executive Vice President
One PaeTec Plaza, 600 Willowbrook Office Park
Fairport, New York 14450

May 8, 2017

Advice Letter No. 177

SECTION 8 - BILLING AND COLLECTION (Cont'd)

8.2 RECORDING SERVICE (Cont'd)

For Feature Group B or 900 Access Service, C, and D Switched Access Service, the term “customer message” used herein denotes an intrastate call originated by a customer’s end user. Station message detail recording is an optional feature which provides a record of customer messages originated by MTS and WATS access lines. Such detail will be provided as part of Feature Group D end office and type of call recording service when requested by the customer. For Feature Group A switched access service, the term “customer message” used herein denotes a call over an intrastate Feature Group A switched access service. A call includes both calls originated to and terminated from a Feature Group A switched access service. The beginning and ending of a customer message are determined pursuant to the written instructions of the customer.

Issued: May 1, 2017

Resolution No:

Issued by:

Richard E. Ottalagana, Executive Vice President
One PaeTec Plaza, 600 Willowbrook Office Park
Fairport, New York 14450

May 8, 2017

Advice Letter No. 177

SECTION 8 - BILLING AND COLLECTION (Cont'd)

8.2 RECORDING SERVICE (Cont'd)

8.2.1 Undertaking of the Company

- A. The company will record all customer messages carried over Feature Group B for 900 access service, C, and D switched access service that are available to company-provided recording equipment or operators. The company will record all customer messages, including interLATA intrastate messages and interLATA interstate messages, carried over a Feature Group A switched access service. Unavailable customer service messages (i.e. certain Feature Group C operator and TOPS messages which are not accessible by company-provided equipment or operators) will not be recorded. The recording equipment will be provided at locations selected by the company.
- B. A standard format for the provision of the recorded customer message detail will be established by the company and provided to the customer. If, in the course of company business, it is necessary to change the format, the company will notify the involved customers six months prior to the change.

Assembly and editing, provision of customer detail, data transmission to a customer location, special orders for recording and program development will be provided to the customer on a contractual basis.

- C. Recorded customer message detail which is used at the request of the customer to provide message processing and message bill processing service is not retained by the company for longer than 45 days. The rates for unbilled message detail and the billed message detail is retained for reference in place of the recorded customer message detail. For recorded customer message detail not used by message processing service at the customer's request, the company will make every reasonable effort to recover recorded customer message detail previously made available to the customer and make it available again for the customer. The charges as set forth in the rate schedule, following, will apply for all such detail provided. Such a request must be made within thirty (30) days from the date the details were initially made available to the customer.

Issued: May 1, 2017

Resolution No:

Issued by:

Richard E. Ottalagana, Executive Vice President
One PaeTec Plaza, 600 Willowbrook Office Park
Fairport, New York 14450

May 8, 2017

Advice Letter No. 177

SECTION 8 - BILLING AND COLLECTION (Cont'd)

8.2 RECORDING SERVICE (Cont'd)

8.2.2 Liability of the Company

Notwithstanding 8.2.1 preceding, the company's liability for recording service is as follows:

Unless there is an expressed written agreement to the contrary, in the absence of gross negligence or willful misconduct, no liability for damages to the customer or other person or entity other than as set forth in (A) and (B) preceding shall attach to the company for its action or the conduct of its employees in providing recording service.

8.2.3 Obligations of the Customer

The customer shall order recording service under a special order.

The customer shall order recording service at least one month prior to the date when the customer message detail is to be recorded, unless customer's request requires that recording service be provided by end office and type of call, then the ordering interval will be determined on an individual case basis.

The customer shall order recording service for Feature Group D switched access by end office and type of call in accordance with the terms and conditions established on an individual case basis special order.

SECTION 8 - BILLING AND COLLECTION (Cont'd)

8.2 RECORDING SERVICE (Cont'd)

8.2.4 Payment Arrangements and Audit Provision

A. Notice and Scope

- 1) Upon forty-five (45) days' prior written notice by the customer to the company (or such shorter period as the parties may mutually agree upon), the customer or its authorized representative shall have the right to commence an audit during normal business hours and at intervals of no more than one audit in any six month period. The audit will be limited to all such records and accounts as may, under recognized accounting practices, contain information bearing upon amounts subject to being billed to the customer's end users by the company as part of its provision of billing and collection services and the changes to the customer for other services provided by the company pursuant to this tariff.
- 2) The written notice of audit shall identify the date upon which it is to commence, the location, the customer's representatives, the subject matter of the audit, and the materials to be reviewed.
- 3) The written notice of audit shall be directed to the company's representative at the address stipulated by such representative.
- 4) The company may, within thirty (30) days of receipt of the customer's notice of audit, postpone commencement by written notice for a period not to exceed fifteen (15) days, but only for good cause. The company shall also indicate the new date for commencement of said audit.
- 5) Upon completion of the audit, the customer's auditors are to provide an oral report of their findings to the company prior to their departure, followed by a letter within thirty (30) days confirming findings.

Issued: May 1, 2017

Resolution No:

Issued by:

Richard E. Ottalagana, Executive Vice President
One PaeTec Plaza, 600 Willowbrook Office Park
Fairport, New York 14450

May 8, 2017

Advice Letter No. 177

SECTION 8 - BILLING AND COLLECTION (Cont'd)

8.2 RECORDING SERVICE (Cont'd)

8.2.4 Payment Arrangements and Audit Provision (Cont'd)

B) Payment of Expense

Each party shall bear its own expenses in connection with the conduct of an audit. Special data extractions required by the customer for its representative to conduct the audit will be paid for by the customer. "Special data extraction" for auditing purposes shall mean programming, clerical and computer time required to create an output record (from existing data files) that cannot normally be created from current software programs in the production program library.

Issued: May 1, 2017

Resolution No:

Issued by:

Richard E. Ottalagana, Executive Vice President
One PaeTec Plaza, 600 Willowbrook Office Park
Fairport, New York 14450

May 8, 2017

Advice Letter No. 177

SECTION 8 - BILLING AND COLLECTION (Cont'd)

8.2 RECORDING SERVICE (Cont'd)

8.2.4 Payment Arrangements and Audit Provision (Cont'd)

C. Requests for Examinations

1. In addition to audits, the customer, or its representatives, may request, from time to time, the opportunity to conduct an examination, as defined in (ii) following. The company will make reasonable efforts to accommodate requests for examination and to cooperate in the conduct of an examination.
2. An "examination" shall, for purposes of this section, constitute a reasonable inquiry on a single issue or a specific topic related to billing and collection service for a stated reason.
3. Upon concurrence by both parties that errors or omissions exist, adjustment shall be made by the proper party to compensate for any errors or omissions disclosed by such examination or audit.

D. Audit Provision

All information received or reviewed by the customer or its authorized representative is to be considered confidential and is not to be distributed, provided or disclosed in any form to anyone not involved in the audit, nor is such information to be used for any other purposes.

E. Minimum Period and Minimum Monthly Charges

The minimum period for which recording service without sorting is provided and for which charges apply is one month.

Issued: May 1, 2017

Resolution No:

Issued by:

Richard E. Ottalagana, Executive Vice President
One PaeTec Plaza, 600 Willowbrook Office Park
Fairport, New York 14450

May 8, 2017

Advice Letter No. 177

SECTION 8 - BILLING AND COLLECTION (Cont'd)

8.2 RECORDING SERVICE (Cont'd)

8.2.4 Payment Arrangements and Audit Provision (Cont'd)

F. Cancellation of a Special Order

A customer may cancel a special order for recording service on any date prior to the service date. The cancellation date is the date the company receives written or verbal notice from the customer that the special order is to be canceled. The verbal notice must be followed by written confirmation within ten (10) days. The service date for recording service is the date the customer requests the recordings to start. When a customer cancels a special order for recording service after the order date but prior to the start of service, a special order charge and the minimum monthly charges will apply.

G. Changes to Special Orders

When a customer requests material changes to a pending special order for recording service, the pending special order will be canceled and the requested changes will be undertaken if they can be accommodated by the company under a new special order. All cancellation charges as set forth in (C) preceding will apply for the canceled special order.

8.2.5 Rate Regulations

The special order charge applies for each special order accepted by the company for recording service or for a subsequently requested change.

SECTION 8 - BILLING AND COLLECTION (Cont'd)

8.3 AUTOMATIC NUMBER IDENTIFICATION

ANI provided the automatic transmission of a seven or ten digit number and information digits to the customer's premises for calls originating in the LATA, to identify the calling telephone number. The ANI feature is an end office software function which is associated on a call-by-call basis with (1) all individual transmission paths in a trunk group routed directly between an end office and a customer's premises or, where technically feasible, with (2) all individual transmission paths in a trunk group between an end office and an access tandem, and a trunk group between an access tandem and a customer's premises.

8.3.1 Rate Regulations

When ANI is delivered (with Feature Group D originating) and the customer is charged the recording rate as set forth in the rate schedule, following, the ANI rate does not apply. If the customer is not charged the recording rate, the ANI rate as set forth in the rate schedule will apply for each ANI record delivered to the customer.

Issued: May 1, 2017

Resolution No:

Issued by:

Richard E. Ottalagana, Executive Vice President
One PaeTec Plaza, 600 Willowbrook Office Park
Fairport, New York 14450

May 8, 2017

Advice Letter No. 177

SECTION 8 - BILLING AND COLLECTION (Cont'd)

8.4 BILLING NAME AND ADDRESS SERVICE

Billing Name and Address (BNA) service is the provision of the complete billing name, street address, city or town, state and zip code for a telephone number assigned by the company.

BNA service is provided for the sole purpose of permitting the customer to bill its telephonic communications services to its end users and may not be resold or used for any other purpose, including marketing activity such as market surveys or direct marketing by mail or by telephone.

The customer may not use BNA information to bill for merchandise, gift certificates, catalogs, or other services or products.

BNA services is provided on both a manual and a mechanized basis. On a manual basis, the information will be provided by voice telecommunications or by mail, as appropriate. On a mechanized basis, the information will be entered on magnetic tape containing recorded customer messages.

BNA information is furnished for sent-paid, collect, bill to third number, 700 and 900 service messages and messages charged to a calling card that is resident in the company's database. In addition, BNA information for messages originated from data terminal numbers (DTNs) of data communications services is furnished on a manual basis only.

Issued: May 1, 2017

Resolution No:

Issued by:

Richard E. Ottalagana, Executive Vice President
One PaeTec Plaza, 600 Willowbrook Office Park
Fairport, New York 14450

May 8, 2017

Advice Letter No. 177

SECTION 8 - BILLING AND COLLECTION (Cont'd)

8.4 BILLING NAME AND ADDRESS SERVICE (Cont'd)

8.4.1 Undertaking of the Company

- A. A request for information on over 100 and up to 500 telephone numbers should be mailed to the company. The company will provide the response by first class U.S. Mail within ten (10) business days.
- B. Upon receipt of a magnetic tape of recorded customer messages, the company will, at the request of the customer, provide BNA service on a mechanized basis. The tape of messages may be provided by the customer or, where the customer subscribes to recording service as set forth in 8.2 preceding, may be the output from that service. The company will enter the BNA information on the recorded message tape and send the tape to the customer by first class U.S. Mail. Other methods of delivering the data may be negotiated, and charges based on cost will apply.

The company will provide a response to customer-provided tapes by mail within six (6) business days of receipt. The company will process and mail tapes which are the output of recording service every fifth business day.

- C. The company will specify the format in which requests and tapes are to be submitted.
- D. The BNA information will be provided for the calling number furnished to the extent a billing name and address exists in the company customer records information system, including non-published and non-listed numbers. If the billing name and address information for a specific calling number is confidential due to legal, national security, end user or regulatory imposed requirements, the company will provide an indicator on the confidential records.
- E. The company will provide the most current BNA information resident in its database. Due to normal end user account activity, there may be instances where the BNA information provided is not the BNA that was applicable at the time the message was originated.

Issued: May 1, 2017

Resolution No:

Issued by:

Richard E. Ottalagana, Executive Vice President
One PaeTec Plaza, 600 Willowbrook Office Park
Fairport, New York 14450

May 8, 2017

Advice Letter No. 177

SECTION 8 - BILLING AND COLLECTION (Cont'd)

8.4 BILLING NAME AND ADDRESS SERVICE (Cont'd)

8.4.2 Obligations of the Customer

- A. With each order for BNA service, the customer shall identify the authorized individual and address to receive the BNA information.
- B. A customer which orders BNA service on a mechanized basis and which intends to submit tapes of record messages for processing must provide the company with an acceptable test tape or transmission which includes all call types for which BNA information may be requested.
- C. The customer shall institute adequate internal procedures to insure that BNA information, including that related to non-published and non-listed telephone numbers, is used only for the purpose set forth in this tariff and that BNA information is available only to those customer personnel or agents with a need to know the information. The customer must handle all billing name and address information designated as confidential by the company in accordance with the company's procedures concerning confidential information. The company will provide to the customer a statement of its procedures concerning confidential information.
- D. The customer shall not publicize or represent to others that the company jointly participates with the customer in the development of the customer's end user records, accounts, databases or market data, records, files and databases or other systems it assembles through the use of BNA service.

Issued: May 1, 2017

Resolution No:

Issued by:

Richard E. Ottalagana, Executive Vice President
One PaeTec Plaza, 600 Willowbrook Office Park
Fairport, New York 14450

May 8, 2017

Advice Letter No. 177

SECTION 8 - BILLING AND COLLECTION (Cont'd)

8.4 BILLING NAME AND ADDRESS SERVICE (Cont'd)

8.4.2 Obligations of the Customer (Cont'd)

- E. When the customer orders BNA service for both interstate and intrastate messages, the projected percentage of interstate use must be provided in a whole number to the company. The company will designate the number obtained by subtracting the projected interstate percentage from 100 (100-projected interstate percentage = intrastate percentage) as the projected intrastate percentage. This whole number percentage will be used by the company to apportion the rates and nonrecurring charges between interstate and intrastate in those circumstances where the recorded message detail is not sufficient to permit the company to determine the appropriate jurisdiction. This percentage will remain in effect until a revised report is received as set forth below.

Issued: May 1, 2017

Resolution No:

Issued by:

Richard E. Ottalagana, Executive Vice President
One PaeTec Plaza, 600 Willowbrook Office Park
Fairport, New York 14450

May 8, 2017

Advice Letter No. 177

SECTION 8 - BILLING AND COLLECTION (Cont'd)

8.4 BILLING NAME AND ADDRESS SERVICE (Cont'd)

8.4.2 Obligations of the Customer (cont'd)

E. (Cont'd)

Effective on the first of January, April, July, and October of each year the customer may update the jurisdictional report. The customer shall forward to the company, to be received no later than 20 calendar days after the first of each such month, a revised report showing the interstate percentage of use for the past three months ending the last day of December, March, June, and September, respectively. Except where jurisdiction can be determined from the recorded message detail, the revised report will serve as the basis for the next three months billing and will be effective on the bill date in the following month (i.e. February, May, August, and November). No prorating or backbilling will be done based on the report. If the customer does not supply the report, the company will assume the percentages to be the same as those provided in the last quarterly report. For those cases in which a quarterly report has never been received from the customer, the company will assume the percentages to be the same as those provided in the order for service.

F. The company shall use reasonable efforts to provide accurate and complete lists. The company makes no warranties, expressed or implied, as to the accuracy or completeness of these lists.

Issued: May 1, 2017

Resolution No:

Issued by:

Richard E. Ottalagana, Executive Vice President
One PaeTec Plaza, 600 Willowbrook Office Park
Fairport, New York 14450

May 8, 2017

Advice Letter No. 177

SECTION 8 - BILLING AND COLLECTION (Cont'd)

8.4 BILLING NAME AND ADDRESS SERVICE (Cont'd)

8.4.3 Rate Regulations

- A. Service Establishment Charges apply for the initial establishment of BNA service on a manual basis, for the initial establishment of BNA service on a mechanized basis and for establishment of a master BNA list for a customer.
- B. A charge applies for each request for BNA information for a telephone number or DTN number on a manual basis. A charge applies for each message processed to supply BNA information on a mechanized basis.

The company will keep a count of the requests and of the messages processed. The company will bill the customer in accordance with these counts whether or not the company was able to provide BNA information for all request and messages.

- C. Where the recorded message detail is sufficient to determine a message is an intrastate message, the rates set forth in the rate schedule following will apply to each such message.

Usage for which the recorded message detail is insufficient to determine jurisdiction will be prorated by the company between interstate and intrastate.

The percentages provided in the reports as set forth in 8.4.2(E) preceding will serve as the basis for prorating the charges. The intrastate charges are determined as follows: For usage sensitive (i.e., requests or messages processed) chargeable rate elements, multiply the intrastate percent times actual use times the stated tariff rate.

- D. When a customer cancels an order for BNA service after the order date, the service establishment charge applies.

SECTION 8 - BILLING AND COLLECTION (Cont'd)

8.5 MEET POINT BILLING

In cases where the Customer chooses to originate and/or terminate its traffic with the Company which then is either sent for termination to another Local Exchange Carrier's (LEC) network or is handed to the Company by a LEC for Company termination, Meet Point Billing (MPB) will apply. MPB means that both the Company and the other LEC will issue bills to the Customer for services rendered per terms of either Parties applicable tariffs or other arrangements or, more commonly, a multiple-bill, multiple tariff arrangement.

It is the obligation of the interconnected LEC, in the instances where traffic is originated via a Company Customer and switched and transported by the Company to interconnected LECs, to contractually arrange with the Company for presentation of records necessary for billing of a Customer's traffic. In the absence of such an arrangement, the Company assumes that interconnected LECs have sufficient information to bill relevant Customer's per their standard billing formats and governing documents.

With this multiple-bill, multiple tariff and meet point connection, both the Company and the other LEC will prepare its own bill and bill charges in accordance with its own tariff. Other arrangements may be made that are mutually agreeable to both the Company and the Customer. Mileage sensitive charges will be proportionately billed in accordance with industry standards.

8.6 CHARGEABLE OPTIONAL FEATURES

800 Database Access Service is provided to all customers in conjunction with switched access service. When a 1+800+NXX-XXXX call is originated by an end user, the Company will utilize the SS7 network to query an 800 database to identify the Customer to whom the call will be delivered, and to provide vertical features based on the dialed digits. The call will then be routed to the identified Customer over switched access.

A Basic or Vertical Feature Query charge is assessed for each query launched to the 800 database. The Basic Query provides for the identification of the customer to whom the call will be delivered and includes area of service routing which allows routing of 800 calls by telephone companies to different interexchange carriers based on the Local Access Transport Area (LATA) in which the call originates. The Vertical Feature Query provides the same customer identification function in addition to vertical features which may include: (1) call validation, ensuring that call originates from subscribed service areas; (2) POTS translation of 800 numbers; (3) alternate POTS translation, which allows subscribers to vary the routing of 800 calls based on factors such as time of day, place of origin of the call, etc.; (4) multiple carrier routing, which allows subscribers to route to different carriers based on factors similar to those in (3).

Issued: May 1, 2017

Resolution No:

Issued by:

Richard E. Ottalagana, Executive Vice President
One PaeTec Plaza, 600 Willowbrook Office Park
Fairport, New York 14450

May 8, 2017

Advice Letter No. 177

SECTION 8 - BILLING AND COLLECTION (Cont'd)

8.7 BLOCKING AND SCREENING:

8.7.1 International Direct Dialed Blocking

International Direct Dialed Blocking Service (IDDB) is an arrangement that prevents the use of certain line-side exchange services for the completion of international direct dialed call. This arrangement recognizes and blocks, by routing such calls to a recorded announcement, any attempt to dial international direct dialed sequences of 011+ or 101XXXX011+.

International Direct Dialed Blocking Service is available for use with the following line-side exchange services

- Centrex
- Private Branch Exchange (PBX)
- Public Telephone Service
- Business Exchange
- Business ISND

In addition, IDDB will be provided with other line-side exchange services on an unbundled basis to all business customers where technically feasible and economically reasonable.

IDDB will be provided from suitably equipped service wire centers as specified in the NATIONAL EXCHANGE CARRIER ASSOCIATION, INC. Tariff F.C.C. No. 4

8.7.2 Originating Line Number Screening:

Origination Line Number Screening (OLNS) Service provides customers with access to the Telephone Company's Line Information Data Base (LIDB) to facilitate the completion of originating calls from working telephone numbers. In response to a properly formatted OLNS query, the Telephone Company will provide the originating screening requirements for call processing and billing that are associated with the originating line.

SECTION 8 - BILLING AND COLLECTION (Cont'd)

8.7 BLOCKING AND SCREENING (Cont'd)

8.7.3 Public Access Line (PAL) Terminating (Billed) Number Screening

PAL Terminating (Billed) Number Screening provides screening of terminating calls to a public Access Line Service as follows:

1. Option A alerts operators throughout the country that collect and third number calls cannot be billed to a particular number
2. Option B alerts operators throughout the country that third number calls cannot be billed to a particular number
3. Option C alerts operators throughout the country that collect calls cannot be billed to a particular number.

PAL Terminating (Billed) Number Screening is available where facilities permit.

8.8 ACCESS SERVICE BILLING INFORMATION

- A. The customer, upon request, has the option of receiving its primary monthly access bill and Customer Service Record (CSR) in one of the following standard medium, at no charge:
1. Paper
 - (a) Detailed paper bill, up to and including 200 pages.
 2. Bill Data Record
 - (a) E-mail (PDF document)
 - (b) Electronic Data Transmission , e-mail SECABS (where available)

Issued: May 1, 2017

Resolution No:

Issued by:

Richard E. Ottalagana, Executive Vice President
One PaeTec Plaza, 600 Willowbrook Office Park
Fairport, New York 14450

May 8, 2017

Advice Letter No. 177

SECTION 8 - BILLING AND COLLECTION (Cont'd)

8.8 ACCESS SERVICE BILLING INFORMATION (Cont'd)

- B. At the option of the customer, and for an additional charge as set forth in 8.8.G following:
1. Additional hard copies of the monthly access bill or service and features record may be provided on paper.
 2. Additional Bill Data Record information may be provided in SECABS format via E-mail (Where available).
 3. Additional Bill Data Record information may be transmitted to the customer premises by email in PDF format.
 4. Printed paper invoices in excess of 200 pages.
- C. The rules and regulations concerning payment arrangements and credit allowances described in Sections 1.3.11, 2.2 and 2.4 preceding, applies to all primary monthly access bills, regardless of the chosen bill medium.
- D. Upon acceptance by the Company of a request for a change in the existing medium of the primary monthly access bill data (e.g. , paper to magnetic tape, magnetic tape to paper, or any of the previous two to electronic data transmission of CD ROM), and for an additional electronic data transmission, the Company, in cooperation with the customer, will determine the interval required to implement the request basis.
- E. Regulations regarding electronic data transmission failure will apply as follows:
1. In the event of transmission failure resulting from Company error, the Telephone Company will re-send a bill by electronic data transmission at no charge to the customer. The bill payment due date will be negotiated between Telephone Company and customer for this bill.

Issued: May 1, 2017

Resolution No:

Issued by:

Richard E. Ottalagana, Executive Vice President
One PaeTec Plaza, 600 Willowbrook Office Park
Fairport, New York 14450

May 8, 2017

Advice Letter No. 177

SECTION 8 - BILLING AND COLLECTION (Cont'd)

8.8 ACCESS SERVICE BILLING INFORMATION (Cont'd)

E. (Cont'd)

2. In the event of transmission failure resulting from failure of the customer's transmission line or other customer error, the Company will re-send a bill by electronic data transmission at the same rates and charges as a request for an additional copy of the access bill as set for in 8.8.G following.
3. In the event that there are problems or disputes regarding receipt of the data transmission other than those outlined in (1) and (2) preceding, the Company will forward a duplicate access bill via email or on CD by overnight delivery. After investigation, if (2) preceding applies, the same rates and charges as a request for an additional copy of the access bill will apply as set forth in 8.8.G following.

F. This service may not be available for non-access rates and charges.

G. The rates and charges for the provisions of Access Service Billing Information are as follows:

	Rates
1. Additional hard paper copies of the customer's monthly bill or service and features record on paper	\$.12 / page + cost of shipping
2. Additional electronic copies (PDF) of the customers monthly bill or service and features record in PDF format sent via electronic transmission	\$0.50 / bill

Issued: May 1, 2017

Resolution No:

Issued by:

Richard E. Ottalagana, Executive Vice President
One PaeTec Plaza, 600 Willowbrook Office Park
Fairport, New York 14450

May 8, 2017

Advice Letter No. 177

SECTION 8 - BILLING AND COLLECTION (Cont'd)

8.8 ACCESS SERVICE BILLING INFORMATION (Cont'd)

G. (Cont'd)

	Rates
3. Additional copies of Call Detail Records via electronic transmission (FTP, NDM, e-mail)	\$0.015 / record
4. Copies of CDR's via CD ROM	\$30.15 / CD
5. Printed paper invoices in excess of 200 pages	
• 201-500 pages	\$100.00
• 501-1000 pages	\$150.00
• 1001-1499 pages	\$200.00
• 1500 pages and over	\$300.00
6. A Service Fee will apply each time a customer orders an additional copy of an invoice or a bill reprint.	
• Service Fee	\$25.00

Issued: May 1, 2017

Resolution No:

Issued by:

Richard E. Ottalagana, Executive Vice President
One PaeTec Plaza, 600 Willowbrook Office Park
Fairport, New York 14450

May 8, 2017

Advice Letter No. 177

SECTION 9 - DESCRIPTION AND APPLICATION OF RATES AND CHARGES

9.1 Usage Rates

Usage rates for switched access service are rates that apply: (1) on a per access minute basis when Direct Access; (2) on a per call blocked basis beyond the blocking threshold for Network Blocking; (3) on a per query basis for 800 Database Queries. All charges are accumulated on a monthly basis. Rates for these services are found in the Rate Attachment.

9.2 Monthly Rates

Monthly rates are flat recurring rates that apply each month or fraction thereof that a chargeable optional feature of basic service element is provided. For billing and prorating purposes, each month is considered to have 30 days.

9.3 Nonrecurring Charges

Nonrecurring charges are one-time charges that apply for specific work activity. The types of non-recurring charges are as follows:

9.3.1 Access Order Charge

The Access Order Charge applies to all Customer requests for new switched access service, and for additions, changes, or rearrangements to existing service. It is applied on a per order basis to each order received by the Company, and is in addition to any other applicable charges as set forth in this and other sections of this tariff.

The Access Order Charge does not apply:

- to administrative changes as set forth in 9.3.2 below;
- when a change in a pending order does not result in the cancellation of the pending order and the issuance of a new order;
- when a Company initiated network reconfiguration requires a Customer's existing access service to be reconfigured.

SECTION 9 - DESCRIPTION AND APPLICATION OF RATES AND CHARGES (Cont'd)

9.3 Nonrecurring Charges (Cont'd)

9.3.2 Installation of Service

Non-recurring charges apply to each Direct Access service installed. This charge applies only when the capacity ordered requires the installation or activation of an additional trunk(s) which is uniquely identified for the sole use of the ordering Customer.

9.3.3 Service Rearrangements

All changes to existing services other than changes involving administrative activities will be treated as the discontinuance of the existing service and an installation of a new service. Installation charges as described in 9.3.2. above apply. Changes and additions to existing services which are necessary due to Company initiated network reconfigurations will be made without charge to the Customer.

Administrative changes include the following:

- change of Customer name;
- change of Customer or Customer's end user premises address when the change of address is not the result of a physical relocation of equipment;
- change in billing data (name, address, contract name or telephone number);
- change of agency authorization;
- change of customer circuit identification;
- change of billing account number;
- change of Customer test line number;
- change of Customer or Customer's end user contact name or telephone number;
- change of jurisdiction.

Issued: May 1, 2017

Resolution No:

Issued by:

Richard E. Ottalagana, Executive Vice President
One PaeTec Plaza, 600 Willowbrook Office Park
Fairport, New York 14450

May 8, 2017

Advice Letter No. 177

SECTION 10 - CURRENT RATES

A. Frontier Exchanges

1. Direct (Dedicated) Access

A.	Local Switching, Per Originating Minute		(C)
	Non-8YY	\$0.013412	
	8YY	*	(C)
	Shared Trunk Port		(C)
	Non-8YY	\$0.001692	
	8YY	*	(C)
B.	Transport Services		
	Transport Termination, per minute		
	All Zones - Originating	\$0.000000	
C.	Transport:		
	DS0 Port, per port, per month	\$44.99	
	DS1 Port, per port, per month	\$147.75	
	DS3 Port, per port, per month	\$8,000.00	
D.	Multiplexing, per arrangement, per month		
	DS3 to DS1	\$124.99	
	DS1 to DS0	\$149.93	
E.	Entrance Facility		
	DS1, per facility, per port, per month	\$174.33	
	DS3, per facility, per port, per month	\$7,200.00	

*Switched access usage is billed at the Company's interstate access rates which are set forth in PAETEC's FCC Tariff No. 3 <https://apps.fcc.gov/etfs/public/tariff.action?idTariff=417> (N)
(N)

Frontier Exchanges include: ALAMITOS, IMPERIAL, LANCASTER, LONG BEACH, ONTARIO, RSVL
MAIN, SIERRAMADR

Issued: June 24, 2021

Resolution No:

Issued by:

Senior Regulatory Counsel
4001 Rodney Parham Road
Little Rock, AR 72212

July 1, 2021

Advice Letter No. 208

SECTION 10 - CURRENT RATES (CONT'D)

A. Frontier Exchanges (Cont'd)

1. Switched Access Service

A. Local Switching

Per Originating Minute

Non-8YY

\$0.01341200

(C)

8YY

*

(C)

Shared Trunk Port

Non-8YY

\$0.00169200

(C)

8YY

*

(C)

B. Transport Services

Transport Termination, per minute

All Zones – Originating

\$0.00000000

Transport Facility, per mile

Originating

(C)

Non-8YY All Zones

\$0.00000200

|

8YY All Zones

*

(C)

(D)

(D)

C. Information Surcharge, per minute

Per Originating Minute

\$0.00000000

Per Terminating Minute

\$0.00000000

*Switched access usage is billed at the Company's interstate access rates which are set forth in PAETEC's FCC Tariff No. 3 <https://apps.fcc.gov/etfs/public/tariff.action?idTariff=417> (N)
(N)

Frontier Exchanges include: ALAMITOS, IMPERIAL, LANCASTER, LONG BEACH, ONTARIO, RSVL
MAIN, SIERRAMADR

Issued: June 24, 2021

Resolution No:

Issued by:

Senior Regulatory Counsel
4001 Rodney Parham Road
Little Rock, AR 72212

July 1, 2021

Advice Letter No. 208

SECTION 10 - CURRENT RATES

B. AT&T California Exchanges

1.	Switched Access Service		
	Originating, per minute		*
2.	Switched Access Service – Direct Connect		
	Originating, per minute		*
3.	Transport:		
	DS0 Port, per port, per month		\$44.99
	DS1 Port, per port, per month		\$147.75
	DS3 Port, per port, per month		\$8,000.00
4.	Multiplexing, per arrangement, per month		
	DS3 to DS1		\$124.99
	DS1 to DS0		\$149.93
5.	Entrance Facility		
	DS1, per facility, per port, per month		\$174.33
	DS3, per facility, per port, per month		\$7,200.00

AT&T California Exchanges include: BREA, CMTN CMTN, DEL MAR, GLENDALE, IRVINE, LANS DA 01, LANS DA 02, LANS DA 13, MOORPARK, NORTHRIDGE, OKLD BKLY, POWAY, SCRM MAIN.

*Originating Rates are billed at the Company's interstate access rates which are set forth in PAETEC's FCC Tariff No. 3 <https://apps.fcc.gov/etfs/public/tariff.action?idTariff=417>

Certain material now found on this Leaf was previously located on Leaf 95.

SECTION 10 - CURRENT RATES (CONT'D)

B. Switched Access

2. Recurring Charge (Cont'd)

D. Terminating Access:

Switched Access Service (Frontier)	*	(C)
Switched Access Service (AT&T California)	*	
Switched Access Service-Direct Connect (Frontier)	*	
Switched Access Service-Direct Connect (AT&T California)	*	(C)
Local Transport Service (Frontier)	*	(C)
Local Transport Service (AT&T California)	*	
Local Transport Service-Direct Connect (Frontier)	*	
Local Transport Service-Direct Connect (AT&T California)	*	(C)

*Terminating switched access usage is billed at the Company's interstate access rates which are set forth in PAETEC's FCC Tariff No. 3 <https://apps.fcc.gov/etfs/public/tariff.action?idTariff=417>

SECTION 10 - CURRENT RATES (CONT'D)

C. Other Services

1.	800 (8YY) Data Base Access Service			(T)	
	<u>Effective</u>	<u>7/1/2021 – 6/30/2022</u>	<u>7/1/2022 – 6/30/2023</u>	<u>7/1/2023</u>	(C)
	Per Query				
	All Areas	\$0.004248 (R)	\$0.002224 (R)	\$0.00020 (R)	(C)
2.	Billing and Collection				
	Recording, per customer message		\$0.034		
	ANI, per attempt		\$0.01183		
3.	Blocking and Screening Service				
	International Direct Dialed Blocking		There is currently no charge		
	Originating Line Screening		There is currently no charge		
	PAL Terminating (Billed) Number Screening		There is currently no charge		
4.	BNA				
	Service Establishment Charge (Non-recurring)		\$144.99		
	Query Charge per Telephone Number		\$0.23		
5.	Non-Recurring Charges				
	Access Order Charge		\$80.99		
	Installation Charge		\$180.99*		
	*Additional charges may apply if labor and/ or other facilities build issues arise.				
	Termination and Blocking Charge – ICB		See section 2.10.6		
6.	ONP Reciprocal Compensation Rates				
	Noncontractual Rate		\$0.0007		